

EPOXY FLOORING SYSTEM BASED ON  
EPOXY RESIN-51-FLOORING.





## TABLE OF CONTENTS

Table of Contents .....	2
WHY CHOOSE ALCHIMICA for FLOORING PROJECTS? .....	4
SPECIALIZED FLOORING SOLUTIONS .....	4
Understanding FLOORING Systems.....	6
ALCHIMICA’S FLOORING SOLUTIONS .....	7
IMPORTANCE OF CHOOSING THE CORRECT FLOORING SOLUTION .....	9
PREPARATION.....	14
REPAIR and LEVELING MORTARS .....	15
REPAIRING.....	15
LEVELING.....	16
PRIMER SELECTION .....	16
SEALING SOLUTIONS .....	17
METHOD STATEMENT .....	20
GENERAL SYSTEM CONDITIONS .....	20
SYSTEM PRODUCTS BUILD-UP .....	24
SUBSTRATE PRIMING .....	<b>Error! Bookmark not defined.</b>
DILATATION JOINTS, INNER ANGLES & SMALL CRACKS ...	<b>Error! Bookmark not defined.</b>
MAIN WATERPROOFING MEMBRANE .....	<b>Error! Bookmark not defined.</b>
TOPCOAT.....	<b>Error! Bookmark not defined.</b>
CLEANING.....	<b>Error! Bookmark not defined.</b>
REPAIRS, OVERLAPS AND MAINTENANCE PROCESS .....	<b>Error! Bookmark not defined.</b>
REFERENCES .....	<b>Error! Bookmark not defined.</b>
HEALTH AND SAFETY .....	39
PRECAUTIONS AND VARIATIONS. ....	39
LEGAL NOTES AND CITATION .....	39



## WHY CHOOSE ALCHIMICA FOR FLOORING PROJECTS?

ALCHIMICA Building Chemicals offers a broad spectrum of flooring systems based on polyurethane, polyurethane-cementitious, and epoxy formulations. These solutions provide excellent chemical, abrasion, and mechanical resistance, designed to withstand high mechanical stresses. Our products are engineered for maximum protection and durability, meeting the highest standards for industrial and commercial flooring. Our solutions cater to various indoor and outdoor applications.

### SPECIALIZED FLOORING SOLUTIONS

- Industrial Flooring:

Our industrial flooring systems include seamless rigid floors with superior abrasion resistance, ideal for heavy traffic industrial environments. We also offer elastic seamless crack-free systems, perfect for hospitals, and food and chemical industries.

- Indoor Car Parks:

We provide seamless polyurethane flooring systems for private or commercial indoor car parks. These coatings withstand high mechanical stresses from traffic, offering high abrasion and slip resistance, along with practical, colorful indicators for parking spots and ramps.

- Decorative Flooring:

Our polyurethane and epoxy decorative flooring systems enhance interiors with high aesthetics and durability. They are suitable for commercial or industrial buildings and available in unlimited colors, combined with colored flakes or matte and granite effects.

- Fitness & Exercise Flooring:



Designed for intensive use, our fitness and exercise flooring systems provide a strong, safe, and comfortable training ground with ultimate durability and resistance to impact stresses. Our polyurethane resin, RUBBER BINDER-M20, can be combined with EPDM or recycled rubber granules for playgrounds, tennis or basketball courts, running tracks, and outdoor recreation areas.

With over 40 years of experience in liquid-applied polyurethane waterproofing systems, ALCHIMICA Building Chemicals offers comprehensive flooring solutions for industrial, commercial, and residential needs. Our commitment to innovation and quality has made us a leader in the construction chemicals industry. We provide advanced polyurethane, epoxy, and cementitious flooring systems that ensure our products are at the forefront of technology. Products like HYPERFLOOR-2K & HYPERDESMO-D-2K offer robust abrasion resistance for high-traffic areas, while HYGROSMART®-PU-CEMENT-3K delivers a seamless, maximum impact surface for industrial applications. EPOXY RESIN 51-FLOORING provides a self-leveling solution with excellent chemical resistance, ideal for environments requiring high hygiene standards.

Understanding the unique requirements of each project, ALCHIMICA offers customizable solutions, including pigmented options to match specific aesthetic preferences. This flexibility is particularly beneficial for decorative flooring in commercial spaces. We provide extensive technical support, offering guidance on product selection, application techniques, and maintenance procedures to ensure optimal results. Committed to sustainability, our products are low in volatile organic compounds (VOCs), 100% solids, and designed for minimal environmental impact. ALCHIMICA stands out for its extensive experience, comprehensive product range, and commitment to innovation and quality. Our flooring systems meet high standards of performance and durability, ensuring long-lasting results. For more information or to discuss your specific project needs, contact us at [alchimica@alchimica.com](mailto:alchimica@alchimica.com). Our experts are ready to provide the guidance and support needed for your project's success.

ALCHIMICA is a pioneer and a global leader in complete polyurethane waterproofing solutions. With extensive expertise in this field, we overcome challenges that others

deem impossible. Our technological depth and know-how allow us to formulate innovative PU-based materials that achieve performance levels not typically met. For 42 years, ALCHIMICA has been active in research, development, and production of building chemicals, providing solutions for liquid waterproofing, reparations, sealing, flooring, and ETICs. Our Research and Development laboratories ensure our solutions meet international industry standards.

## UNDERSTANDING FLOORING SYSTEMS

Flooring systems serve critical functions in various environments by providing durability, protection, safety, aesthetics, and hygiene. Their primary purpose is to protect the underlying concrete or substrate from wear and tear, extending the life of the floor and offering resistance to chemicals, abrasion, and mechanical stresses, making them suitable for demanding environments. Flooring systems improve safety by providing slip resistance, crucial in areas with heavy foot traffic or where liquids are present and can include features such as impact resistance and fire resistance. They also enhance the visual appeal of spaces through decorative options in various colors and finishes, contributing to the overall aesthetic of the building. Seamless flooring systems prevent the accumulation of dirt and bacteria, making them easier to clean and maintain, which is ideal for environments requiring high hygiene standards such as hospitals and food processing facilities. The importance of flooring systems lies in their ability to protect infrastructure, enhance performance, and ensure compliance with safety and hygiene standards, reducing the need for frequent repairs and maintenance.

Flooring systems can be implemented in various settings based on specific needs. In industrial settings like factories and warehouses, floors endure heavy machinery, chemical spills, and high traffic, requiring seamless rigid floors with excellent abrasion resistance. Commercial spaces like offices and retail areas benefit from polyurethane and epoxy decorative flooring systems that offer both aesthetic appeal



and durability. Indoor car parks require coatings that withstand high mechanical stresses from vehicles, providing abrasion and slip resistance. Fitness and exercise flooring, used in gyms and sports courts, offer impact resistance and comfort, often incorporating polyurethane

resin with EPDM or recycled rubber granules. In the healthcare and food industries, floors must meet stringent hygiene standards, be easy to clean, and resistant to chemicals, making elastic seamless crack-free flooring systems ideal.

## ALCHIMICA'S FLOORING SOLUTIONS

ALCHIMICA's flooring systems include polyurethane, epoxy, and cementitious options, each designed for specific applications. Polyurethane flooring is suitable for light to high traffic industrial areas, hospitals, and food industries, offering a seamless, crack-free surface with high resistance to mechanical and chemical stresses. Epoxy flooring is ideal for heavy traffic industrial floors, hospitals, and chemical industries due to its high abrasion resistance and seamless finish. Polyurethane-cementitious flooring provides maximum durability for industrial floors, particularly in food, beverage, pharmaceutical, and chemical industries, requiring high mechanical and chemical resistance. Each system ensures optimal performance and longevity, tailored to meet the unique demands of different environments.

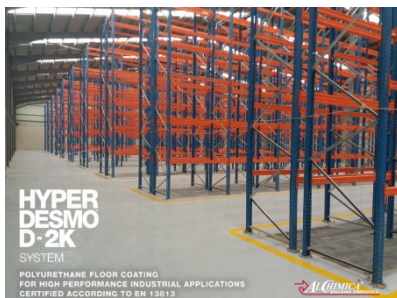

### *POLYURETHANE FLOORING*

Polyurethane flooring is renowned for its flexibility and resilience, providing a seamless, crack-free surface that can withstand a wide range of temperatures and mechanical stresses. It is highly resistant to chemicals, making it ideal for environments where chemical spills are common. Its elastic nature helps absorb impacts, reducing damage and extending the floor's lifespan.



Our polyurethane flooring solutions, such as HYPERFLOOR-2K and HYPERDESMO®-D-2K, are perfect for light to high traffic industrial areas, hospitals, food industries, chemical industries, sports courts, playgrounds, and cold storage rooms. These products offer seamless, flexible surfaces with high resistance to mechanical and chemical stresses, fast curing times, and excellent adhesion. Additionally, their ability to remain elastic in low temperatures

makes them an excellent choice for cold storage rooms, ensuring durability and performance even in harsh conditions.

### *EPOXY FLOORING*

Epoxy flooring is renowned for its hardness and high abrasion resistance, providing a durable, seamless finish that can handle heavy traffic and mechanical wear. It is also chemical-resistant, making it ideal for environments with frequent spills and chemical exposure, and is easy to clean and maintain, offering

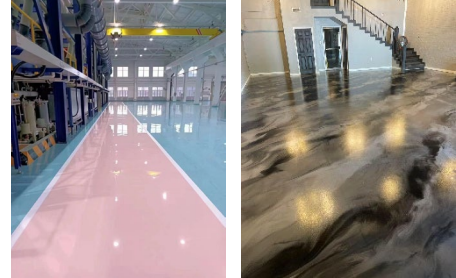

a hygienic surface suitable for various industrial and commercial applications. Our epoxy flooring solutions, including EPOXY RESIN 51-FLOORING, are perfect for heavy traffic industrial floors, hospitals, chemical industries, food processing facilities, and indoor car parks. These products provide excellent abrasion resistance, UV and chemical protection, and flexibility for treating dilatation joints.



### *POLYURETHANE-CEMENTITIOUS FLOORING*

Polyurethane-cementitious flooring systems offer maximum durability and are designed for environments requiring high mechanical and chemical resistance. These floors are ideal for industrial settings demanding the utmost robustness and longevity and are suitable for areas needing strict hygiene standards. Our polyurethane cementitious flooring solution, HYGROSMART®-PU-CEMENT-3K, caters to the food and beverage industry, pharmaceutical industry, healthcare areas, electronics, mechanical engineering, and outdoor industrial floors. This product delivers superior mechanical, physical, and chemical resistance, is non-toxic, and suitable for contact with food, beverages and water.

The main differences between these flooring types lie in their flexibility, application areas, and specific benefits. Polyurethane is more flexible, making it suitable for environments where impact resistance is crucial, while epoxy is harder and provides excellent abrasion resistance, ideal for heavy traffic industrial areas. Polyurethane-cementitious systems offer the highest durability and resistance for the most

demanding industrial environments, surpassing epoxy floors in handling extreme conditions. Each flooring type offers unique benefits tailored to specific applications, ensuring that ALCHIMICA's products provide optimal solutions for various industrial, commercial, and specialized environments.

## IMPORTANCE OF CHOOSING THE CORRECT FLOORING SOLUTION

Selecting the appropriate flooring solution for each project is crucial, impacting functionality, safety, durability, and overall project success.

- **Functionality and Performance**

Each project has specific requirements, and the right flooring system ensures these needs are met. For instance, industrial environments with heavy machinery and high traffic need floors that can withstand significant mechanical stresses and abrasion. Using a flooring system not designed for such conditions can lead to premature wear, frequent repairs, and costly downtime. Conversely, decorative flooring in commercial spaces must prioritize aesthetics while providing durability and ease of maintenance.

- **Safety**

Safety is paramount in any environment, and the right flooring solution significantly enhances it. Slip-resistant surfaces are essential in areas prone to spills or where liquids are frequently present, such as hospitals, kitchens, and food processing plants. An inappropriate flooring system can increase the risk of accidents, compromising safety for employees, clients, and other users.

- **Durability and Longevity**

Different environments subject floors to varying levels of stress, from foot traffic and heavy loads to chemical exposure and temperature fluctuations. Using a flooring system designed for these conditions ensures long-lasting performance and reduces the need for frequent repairs or replacements. For example, epoxy flooring's high abrasion resistance makes it suitable for heavy traffic areas, while polyurethane's flexibility and chemical resistance make it ideal for areas with frequent chemical spills and temperature changes.

- **Hygiene and Maintenance**

In healthcare facilities, food processing plants, and other environments requiring high hygiene standards, seamless flooring systems that prevent dirt and bacteria accumulation are essential. These floors are easier to clean and disinfect, ensuring

compliance with hygiene regulations and maintaining a safe environment. Choosing a flooring system that is difficult to clean or prone to harboring contaminants can lead to health risks and regulatory issues.

- **Cost-Effectiveness**

Selecting the correct flooring solution is also a matter of cost-effectiveness. While the initial investment in a high-quality, appropriate flooring system might be higher, it often results in lower long-term costs due to reduced maintenance, repairs, and replacements. Conversely, opting for a cheaper, unsuitable flooring solution can lead to frequent issues, higher maintenance costs, and potential operational disruptions.

- **Aesthetics and User Experience**

In commercial and residential applications, the appearance of the flooring significantly impacts the overall aesthetic and user experience. Decorative flooring solutions, such as those offered by ALCHIMICA, provide a wide range of colors and finishes that enhance the visual appeal of the space while ensuring durability and functionality. Choosing the wrong flooring system can detract from the intended design and user experience, affecting customer satisfaction and business success.

- **Environmental Impact and Sustainability**

Choosing the correct flooring solution also involves considering the environmental impact and sustainability of the materials used. As the construction industry increasingly prioritizes eco-friendly practices, selecting flooring systems that are environmentally responsible can significantly contribute to a project's sustainability goals. Modern flooring solutions often incorporate materials and manufacturing processes that minimize their environmental footprint. For example, many of ALCHIMICA's products are solvent-free and 100% solids, making them safer for the environment and human health. Using solvent-free products helps reduce air pollution and improves indoor air quality, creating healthier spaces for occupants. Additionally, the longevity and durability of high-quality flooring systems mean less frequent replacements, reducing the overall consumption of materials and energy associated with manufacturing, transportation, and installation. Choosing sustainable flooring solutions supports environmental conservation and can enhance a project's appeal to environmentally conscious clients and stakeholders, contributing to certifications such as LEED (Leadership in Energy and Environmental Design), which recognizes buildings that meet high standards of environmental performance.

In summary, selecting and using the correct flooring solution for each project application is vital for ensuring functionality, safety, durability, hygiene, cost-effectiveness, regulatory compliance, and aesthetic appeal. Tailoring the flooring system to the specific needs of the environment maximizes the performance and lifespan of the floor, contributing to the overall success and sustainability of the project. By considering environmental impact and sustainability, and opting for eco-friendly, durable, and solvent-free, 100% solids flooring systems, you can support environmental sustainability, improve indoor air quality, and enhance the overall appeal and credibility of your projects. This comprehensive approach ensures that every aspect of flooring performance is optimized for the unique demands of each application.

## EPOXY RESIN 51-FLOORING: THE OPTIMAL SOLUTION FOR EPOXY FLOORING

When it comes to epoxy flooring, the demands on materials are high due to mechanical stresses, chemical exposures, and varied environmental conditions. ALCHIMICA's EPOXY RESIN 51-FLOORING stands out as an ideal solution for a wide range of flooring applications, including industrial, commercial, and specialized environments. Here's why:

- ✓ Exceptional Adhesion and Compatibility

EPOXY RESIN 51-FLOORING offers robust adhesion to various substrates, including concrete and metal. This ensures a secure bond even under extreme conditions encountered in industrial and commercial settings. The use of primers like AQUADUR or AQUASMART-DUR enhances adhesion on both porous and non-porous surfaces, making it versatile for different project requirements.

- ✓ Superior Material Properties

- High Impact and Abrasion Resistance: EPOXY RESIN 51-FLOORING is a two-component, self-leveling, solvent-free epoxy material that boasts excellent mechanical properties. It offers high impact and abrasion resistance, ensuring the flooring remains intact and functional under heavy traffic and extreme conditions.

- **Chemical Resistance:** The formulation provides excellent chemical resistance, making it suitable for environments exposed to harsh chemicals, such as food processing, pharmaceutical industries, and hospitals.
- **Inhibits Fungal and Bacterial Growth:** This property is particularly important for maintaining hygiene standards in sensitive environments like hospitals and food industries.

✓ **Ease of Application**

One of the significant advantages of EPOXY RESIN 51-FLOORING is its user-friendly application process. The material can be applied using a roller or spatula in two coats, conforming easily to irregular surfaces and intricate details. This versatility makes it suitable for a range of substrates and conditions. Its fast-curing nature allows for rapid application, minimizing downtime during construction projects.

✓ **Certified Performance**

This flooring system is CE certified according to EN 13813, ensuring compliance with stringent industry standards for indoor applications. The certification guarantees its long-term performance and reliability, providing confidence in its use across various industries.

✓ **Proven Success Worldwide**

EPOXY RESIN 51-FLOORING has been successfully used in numerous projects around the globe, demonstrating its reliability and effectiveness in real-world applications. ALCHIMICA's extensive portfolio of completed projects showcases the versatility and success of this material in diverse settings. References and additional certificates are available upon request at [alchimica@alchimica.com](mailto:alchimica@alchimica.com)

✓ **Comprehensive Support and Technical Assistance**

For specific project requirements, ALCHIMICA provides detailed technical support and guidelines to ensure the correct application of EPOXY RESIN 51-FLOORING. This support helps construction professionals achieve optimal results and maintain the integrity of their flooring systems over time.

✓ **Cost Efficiency and Sustainability**

EPOXY RESIN 51-FLOORING not only offers superior performance but also contributes to cost efficiency and sustainability. Its long service life reduces the need for frequent replacements and maintenance, leading to significant cost savings over

time. Additionally, its solvent-free formulation ensures a minimal environmental impact, aligning with green building practices and sustainability goals.

EPOXY RESIN 51-FLOORING is the ideal material for epoxy flooring, offering exceptional adhesion, superior mechanical properties, and proven long-term performance. Its high impact and abrasion resistance ensure durable and reliable flooring solutions, while its compatibility with various substrates and topcoat systems enhances its versatility. Fast curing and easy application reduce project downtime, promoting efficiency and quicker completion. Certified to meet stringent industry standards, EPOXY RESIN 51-FLOORING ensures safety and regulatory compliance. With comprehensive support from ALCHIMICA, construction and infrastructure companies, as well as contractors, can confidently implement this flooring system, ensuring the success and longevity of their projects. The added benefits of cost efficiency and sustainability further underscore EPOXY RESIN 51-FLOORING as the optimal choice for epoxy flooring applications.

## EN 13813

EN 13813 is a European standard that specifies the requirements for screed materials used in constructing floor screeds, ensuring high-quality and durable flooring solutions. This standard applies to a variety of screed materials including cementitious, calcium sulfate, magnesite, mastic asphalt, and synthetic resin screeds, each tailored to meet specific properties and performance criteria for different applications and environments.

These materials are primarily intended for internal applications, although cementitious screeds can also be used externally. Each type is defined with particular properties to suit different construction needs and environments. The standard details the essential properties and performance criteria for both fresh and hardened screed materials. These include working time, consistency, pH value, compressive strength, flexural strength, wear resistance, surface hardness, shrinkage, swelling, modulus of elasticity, and bond strength. These properties are crucial to ensure that the screeds can withstand the demands of their intended applications and provide long-lasting performance. Surface preparation is another critical aspect covered by EN 13813. Proper preparation of the substrate is vital for achieving strong adhesion

between the screed and the underlying surface. This involves cleaning the substrate, removing any contaminants, and possibly applying primers or bonding agents to enhance adhesion. This step is essential to maximize the performance and durability of the screed material. The standard also provides detailed guidelines for the application of screed materials. These guidelines include mixing, placing, and curing procedures to ensure that the screed is applied correctly. Following these procedures is essential for achieving the desired performance and longevity of the flooring. Quality control measures are integral to EN 13813, ensuring that screed materials consistently meet the specified requirements throughout the manufacturing and application process. Regular testing of properties such as compressive and flexural strength, wear resistance, and bond strength is necessary to verify compliance with the standard and to ensure the reliability of the screed materials.

By adhering to EN 13813, construction professionals can ensure the quality, safety, and longevity of floor screeds, contributing to the overall durability and functionality of buildings. This standard supports sustainable construction practices by promoting the use of high-quality, reliable screed materials, thus enhancing the sustainability and preservation of building infrastructure.

## PREPARATION

For successful and safe waterproofing applications specific tools and equipment are required. Each application might have different requirements.

Minimum application equipment includes protective clothing, a 1KW slow-speed drill, and a brush, roller, or airless spray machine for mixing and application. Before installing the system, the weather working conditions should be considered in order to ensure the correct and safe application of the system. Overall, avoid extreme cold or hot surface conditions. In case of high heat, contractors may apply the products either in the morning or afternoon. The application temperature range is 5°C to 35°C, with no dew point conditions, a maximum 95% relative humidity, and substrate temperature above 3°C. Store materials cool, tools dry, and avoid application during hot hours.



Substrate: To ensure successful application, substrate preparation is crucial. New concrete should be at least 28 days old, clean, dry, and free of substances that could reduce adhesion. Dust removal is recommended, and Alchimica's primer application can be done over damp concrete.

*In case of doubtful conditions, please contact ALCHIMICA's technical assistance for instructions.*

## REPAIR AND LEVELING MORTARS

### REPAIRING

In case any spots on the concrete surface require repairs, filling, and/or smoothing such as large cracks, cavities, or surface levelling, ALCHIMICA's HYGROSMART® range of cementitious mortars may be used:



1. **HYGROSMART®-FIX&FINISH** (Single component, rapid-setting shrinkage-compensated, thixotropic, fiber-reinforced, cementitious mortar applied in a single layer from 3 to 40 mm thick, for repairing and smoothing concrete, certified according to EN1504-03, Type R4 CLASS III), or

2. **HYGROSMART®-BUILDING-45-THIXO** (Single-component, shrinkage-compensated, thixotropic, fiber-reinforced cementitious repair mortar, certified according to EN1504-03, Type R4 CLASS III), or

3. **HYGROSMART®-BUILDING-F** (Single-component, reinforced, quick-setting, cementitious repair mortar with excellent adhesion and mechanical properties, easy application in horizontal/vertical substrates. Long pot life allows the application of thick coats without cracking. CE Certified as Class R3 class III repair mortar according to EN 1504-03.

4. **HYGROSMART®-MAK-FLOW** (Single-component, highly flowable and shrinkage compensated mortar for structural repairs and anchoring, certified according to EN 1504-6: 2006 (Anchoring cementitious mortar for strengthening concrete by installing reinforcing steel) and EN 1504-3: 2005, Class R4(Hydraulic

mortar (R4-CC) for structural repair of concrete in building and civil engineering works).

## LEVELING

In cases where the concrete needs to be levelled or slopes need to be created prior to the installation of the waterproofing membrane, the following products from the HYGROSMART® range can be used, depending on the requirements and desired outcome.

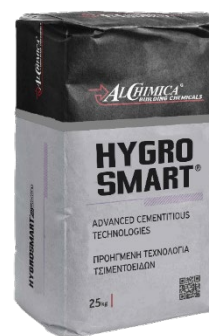

### 1. HYGROSMART®-MAK FLOW (as described above)

## PRIMER SELECTION

After checking the weather conditions and having completed the substrate preparation along with any repairs that might be needed, you can start the waterproofing system's build-up with the selection of a suitable primer. ALCHIMICA's primer range provides unique properties for different substrates.

SUBSTRATE AND CONDITIONS	CONCRETE	HUMID CONCRETE	GYPHUM	METAL STEEL	POROUS CERAMIC TILES	GLASS / GLAZY TILES	PVC MEMBRANES	TPO MEMBRANES	BITUMEN MEMBRANES	LOW TEMPERATURE APPLICATION	VAPOR BARRIER	NEGATIVE PRESSURE / RISING HUMIDITY (t/m <sup>2</sup> )
<b>PU PRIMERS</b>												
PRIMER-PU	X	-	-	X	-	-	-	-	-	-	-	-
MICROPRIMER-PU	X	-	-	X	X	-	-	-	-	-	-	-
MICROSEALER-PU	X	X	X	X	X	-	-	-	-	-	-	-
MICROSEALER-50	X	X	X	X	X	-	-	-	-	-	-	-
GEODESMO 50	X	X	-	X	-	-	-	-	-	X	-	-
UNIVERSAL PRIMER-2K 4060	X	X	-	-	-	-	-	-	X	X	-	-
PRIMER T	-	-	-	-	-	X	-	-	-	-	-	-
PRIMER W	-	-	-	-	-	X	-	-	-	-	-	-
PRIMER TPO/FPO	-	-	-	-	-	-	-	X	-	-	-	-
PRIMER PVC	-	-	-	-	-	-	X	-	-	-	-	-
<b>WATER-BASED PRIMERS</b>												
AQUADUR	X	X	X	-	-	-	-	-	-	-	X	X
AQUASmart-DUR	X	X	X	-	-	-	-	-	-	-	X	X
AQUASmart-PRIMER PU-2K	X	X	-	-	-	-	-	-	X	-	-	-

ALCHIMICA's primers are designed to secure your waterproofing application in every substrate by strengthening the substrate, stabilizing, and sealing it, offering remarkable adhesion with their respective main membranes and sealants.

## SEALING SOLUTIONS



HYPERSEAL® range of PU sealants is essential in sealing applications due to its exceptional adhesion and elasticity, which ensures a durable seal even with the metal's natural expansion and contraction. Its robust formulation offers superior resistance to weathering and UV, making it an ideal choice for both repair and detail treatment in the harsh environment.

Additionally, HYPERSEAL® sealants provide a waterproof seal that prevents leaks, safeguarding the structure from water damage and corrosion, which is vital for maintaining the integrity of tank lining systems over time. HYPERSEAL®-EXPERT-150 and HYPERSEAL®-EXPERT-60FC are both high-performance polyurethane sealants from ALCHIMICA, but they serve different purposes and conditions. HYPERSEAL®-EXPERT-150 is a low-modulus sealant, making it ideal for high humidity conditions and ensuring a bubble-free cure, which is critical in large expansion joints. With an impressive elongation of over 700%, it's designed to accommodate significant movement, making it well-suited for dynamic joints. On the other hand, HYPERSEAL®-EXPERT-60FC is a fast-curing sealant with a higher hardness and chemical resistance, recommended for cold environments, tanks and areas where contact with water polluting liquids occurs, such as petrol stations or secondary containment structures. Its fast tack-free time makes it preferable for projects requiring a quick return to service. Both products offer excellent adhesion to a variety of substrates including metal, but their different physical properties make them suitable for specific conditions encountered in metal roof applications. HYPERSEAL® sealants are available in various colors and compatible with a wide range of construction materials in general. Can be easily applied using standard caulking or gun techniques. Choose the suitable HYPERSEAL® sealant for your project requirements.

## HYPERSEAL®-EXPERT-150

HYPERSEAL®-EXPERT-150 is a low-modulus expansion and construction joints PU sealant designed to ensure a bubble-free cure even in high temperature and humidity conditions. It exhibits excellent thixotropy, making it suitable for large expansion joints. The ratio width to depth should be 2:1 subject to a minimum depth of 10mm. It cures by reacting with atmospheric humidity, producing a joint sealant with a 50% joint movement accommodation factor, elongation >700% (ASTM D412 / EN-ISO-527-3), and excellent adhesion to a variety of substrates (Adhesion to concrete >20 kg/cm<sup>2</sup> (>2 N/mm<sup>2</sup>) ASTM D4541) with or without the use of special primers. The sealant's extrusion rate and tooling remain consistent across various temperature and humidity conditions.

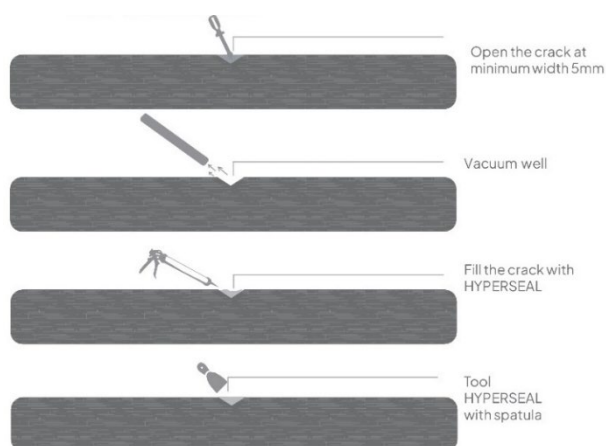
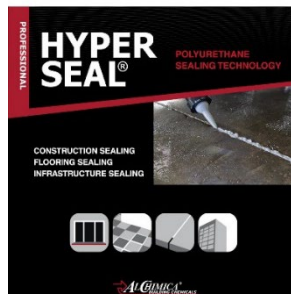

HYPERSEAL®-EXPERT-150 is CE certified according to EN 15651-1:2012 (Sealants for Facades) and 15651-4:2012 (Sealants for Floor Joints with Foot traffic). HYPERSEAL®-EXPERT-150 is a highly flexible PU sealant, with

elastic recovery of >70% (EN ISO 7389) allowing for the movement and expansion of structure components, preventing cracks, and ensuring a lasting seal. It adheres to various substrates, making it durable and able to withstand harsh environmental conditions and heavy traffic loads. As a PU sealant, it is also chemically resistant, protecting the structure from corrosion. Because of its excellent chemical and hydrolysis resistance, it is widely used for sealing joints in swimming pools and chemically treated water environments. HYPERSEAL®-EXPERT-150 provides excellent waterproofing, preventing moisture ingress, and has high elasticity, allowing for flexibility and elasticity. It does not shrink as it cures, ensuring no gaps or openings in the sealed joint. Its excellent heat resistance makes it suitable for application where exposure to temperatures >60°C takes place and its resistance to cold allows the sealant to remain elastic even down to -40°C (service temperature range -40 to +80°C). It has tack free time (@ 77°F (25°C) & 55% RH) of 2.5-3.5 hours and

a cure rate of 2-3 mm/day, low VOC content, and remains resistant and unaffected by microorganisms, fungi, and algae growth, making it the most versatile PU sealant, usable in a variety of applications.

### **HYPERSEAL®-EXPERT 60FC**

For sealing applications where quick return to service is crucial and chemical resistance is a priority, HYPERSEAL®-EXPERT-60FC is the sealant of choice, offering fast curing times and robust adhesion to a variety of surfaces. HYPERSEAL®-EXPERT 60FC stands out as a fast-curing polyurethane sealant, designed for high-performance sealing, providing excellent early grab adhesion even on challenging substrates such as aluminum, steel, and polycarbonate found in metal roofing applications. With its remarkable chemical resistance and resilience to microorganisms and fungus, it is an ideal sealant for metal roof joints exposed to harsh environmental conditions and those requiring contact with water or water-polluting liquids. Moreover, HYPERSEAL®-EXPERT 60FC assures a durable seal in metal roofing with an exceptional elongation rate over 600%, ensuring that the seal remains intact and flexible, accommodating the natural movement of the metal without compromise, even in the most demanding of sealing and repair scenarios. For metal roof applications, HYPERSEAL®-EXPERT 60FC offers a swift and dependable sealing solution with its fast-curing properties and high hardness, ensuring quick return to service and long-lasting performance. Its exceptional adhesion capabilities make it suitable for a variety of metal surfaces, including challenging ones like aluminum and steel, eliminating the need for special primers in many cases. The sealant's robust chemical resistance and resilience to environmental factors, including UV exposure, provide a reliable defense against the elements, making HYPERSEAL®-EXPERT 60FC an advantageous choice for both the repair and detail treatment of metal roofs. Its fast curing profile, is making it ideal for cold climates and challenging weather conditions.

## METHOD STATEMENT

### EPOXY FLOORING SYSTEM BASED ON EPOXY-RESIN-51-FLOORING

#### GENERAL SYSTEM CONDITIONS

#### EQUIPMENT

For successful and safe applications specific tools and equipment are required. Each application might have different requirements in terms of application and protection equipment.

The following application equipment is at minimum required:

- Protective clothing: Protective overalls, masks, and gloves.
- Mixing equipment: 1KW slow speed drill, 400 or 500 rpm, and suitably sized mixing vessel.
- When stirring (or pigmenting) take care not to introduce air into the fluid, which may result in bubbling on the cured membrane. Stirring can either be done manually or with a low speed (300 rpm) mixer.
- Application equipment: Brush, roller, notched trowel, squeegee, rubber spatula, caulking gun, spatula. Specific airless spray machines can also be used. Caulking guns.
- Extra equipment: Digital scale or other measuring equipment

Products can be applied with a variety of equipment. Please choose the desired equipment and method of

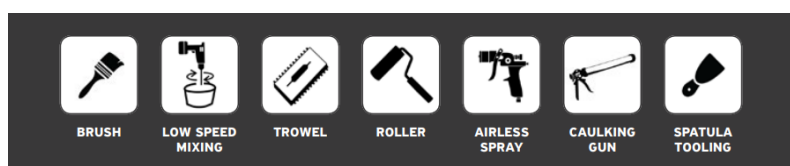

application according to your preferences and experience after consulting the proposed method of application on TDS of the Product.

#### DISCLAIMER: IMPORTANCE OF EQUIPMENT CLEANING

To maintain the integrity and efficacy of products, especially when working with liquid chemicals, it is

*Use clean equipment when switching from different products, to prevent contamination between different products.*

crucial to use equipment that is thoroughly cleaned prior to use. Residual chemicals on containers, mixers, or other tools can initiate unintended chemical reactions or cause contamination **when switching between different products**. Such occurrences may lead to product degradation, and project failure. Adherence to rigorous cleaning protocols is essential to prevent these risks. All users must strictly follow the equipment cleaning guidelines specified herein to ensure product performance and project success.

## WORKING WEATHER CONDITIONS

---

- Application temperature range: 5°C to 35°C.
- Avoid dew point conditions during application.
- Relative humidity must be a maximum of 95% and substrate temperature must be at least 3°C above measured dew point temperatures.
- Do not apply under rain or snow.
- If temperature is above 35°C, the following guidelines are recommended:
  - Store materials in a cool environment, avoiding exposure to direct sunlight.
  - Keep application tools cool and dry.
  - Try to avoid application during the hottest hours of the day.

## SURFACE PREPARATION

---

*THE FOLLOWING FACTORS PRIOR TO APPLICATION SHOULD BE CHECKED:*

- ✓ Substrate type and condition.
- ✓ Previous substrate mechanical preparations (sanding, polishing, shot blasting, or milling)
- ✓ Porosity of the surface
- ✓ Existing cracks or damaged areas.
- ✓ In existing dilatation joints, remove old material, clean it, and replace it with HYPERSEAL®.
- ✓ Existing membranes or coatings.
- ✓ The substrates must be both durable and cohesive. Check the substrate for contamination (oil, grease, etc.).

### *CONCRETE SUBSTRATES*

Concrete substrates are used in the construction of roofs and foundations in modern architectural designs. However, because concrete is a porous surface exposed to different climatic conditions, it can absorb water which can then cause damage. Waterproofing is a basic need at almost all stages of construction work, in order to protect structures from the adverse effects of moisture and water ingress. In the case of exposed concrete roofs, it is vital to avoid any water leak in order to prevent any wear and corrosion of reinforcing steel in the concrete structure.

ALCHIMICA's high-quality concrete roof waterproofing and protection systems consist of quality products that hold excellent workability, durability, elasticity, and resistance to weather, chemical, mechanical, and thermal effects, as well as to UV radiation on either flat or sloping roofs.

#### Standard concrete substrate conditions

- Hardness: R28 = 15 MPa.
- Humidity: W < 10%.
- Temperature: 5-35 °C.
- Relative humidity: < 85%

### *PREPARATION*

Proper preparation of the concrete substrate is essential for complete adhesion and successful application.

- The concrete substrate, on top of which the industrial floor will be applied, must be strong enough with a minimum strength of C20/25.
- The substrate needs to be waterproofed and protected against rising humidity.
- New concrete or other cementitious substrate should be at least 28 days old.
- The humidity levels of the substrate need to be below 4%.
- The substrate should be clean, dry, and free of loose particles, oil, and grease.
- Substrate should be free of any irregularities and flat. If needed, the concrete surface should be ground with the appropriate mechanical equipment in order to remove the cement top skin and achieve a strong and smooth concrete surface.
- The substrate should be free of dust. Vacuum treatment with an industrial vacuum cleaner and/or high-pressure washing is recommended to remove dust.
- Metal details should be free of rust, oils, and old paints.
- The surface of PVC pipes should be treated with sandpaper in order to become rough.

- If there are areas/spots where the original metal roof paint (or possibly anodized aluminum color) has been damaged or worn out, you should remove these old paints or old waterproofing coats (if any), mold, and/or corrosion before proceeding with priming.
- Primer application can be done over damp concrete too. But any ponding water should be removed before primer application.
- Surface irregularities can be filled with the appropriate HYGROSMART® products.
- For concrete leveling or sloping, the appropriate HYGROSMART® products must be used.
- For more information about surface preparation, please contact our technical assistance team.



#### *DILATATION JOINTS AND INNER ANGLES. SPOTS TO REPAIR*

In case there are any spots on the concrete surface that need to be repaired, filled or smoothed such as large cracks and cavities, you can either use HYGROSMART-MAK-FLOW (one-component, cementitious repair mortar, certified according to EN 1504-6 and EN 1504-3 (Class R4), HYGROSMART-BUILDING-45-THIXO (one-component, fiber reinforced cementitious repair mortar, CE certified as Class R4 repair mortar according to European Standard EN 1504-03), HYGROSMART-FIX&FINISH (one-component, rapid-setting shrinkage-compensated, thixotropic, fiber-reinforced, cementitious mortar, CE certified as Class R4 repair mortar according to European Standard EN 1504-03) or EPOXY RESIN-21 T (two-component, thixotropic repair epoxy paste).



Any cracks on the surface must be opened by using a stone wheel, thoroughly cleaned and filled with HYGROSMART-MAK-FLOW, HYGROSMART-BUILDING-45-THIXO, HYGROSMART-FIX&FINISH

or EPOXY RESIN-21 T.

On the perimeter of the floor and in a distance of 20cm from its sides, joints need to be carved at a width and depth of 1cm. Joints of the same dimensions need to be carved around channels, columns, embedded machinery, as well as opposite existing joints and any other part of the surface that is deemed necessary by the contractor, depending on the room's geometry.







#### MANDATORY DISCLAIMER BEFORE APPLICATION:

Testing the products to be used in this build-up application on the specific substrate and conducting mock-up tests are essential steps to ensure good adhesion. Mock-up tests replicate real-world conditions and provide a practical way to evaluate the performance of the products in situ. Pull-out tests conducted on these mock-ups help assess the bond strength between the products and the substrate, giving valuable insights into their adhesion capabilities.

By testing the products on the specific substrate and conducting mock-up tests, any potential issues or concerns regarding adhesion can be identified and addressed before full-scale implementation. This proactive approach helps mitigate risks associated with poor adhesion, ensuring the long-term durability and effectiveness of the build-up system.

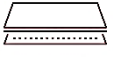
ALCHIMICA advises the thorough testing of the system to be performed prior to proceeding with full surface application in order to determine the suitability of the system based on project requirements.

## SYSTEM PRODUCTS BUILD-UP

	PRODUCT	CONSUMPTION	
1. PRIMER	AQUASMART-DUR	150-200 gr/m <sup>2</sup>	 TOTAL ADHESION
	AQUASMART PU PRIMER 2K	Subject to porosity	
	UNIVERSAL PRIMER 2K 4060		
2. SEALANT	HYPERSEAL®-EXPERT-150	Subject to project needs	 PONDING WATER RESISTANCE
3. MAIN FLOORING COAT	HYPERDERFLOOR-2K	Minimum Total consumption: 2.6 kg/m <sup>2</sup>	
4. STAIN FLOOR PROTECTION & TRAFFIC LINE MARTING (OPTIONAL)	AQUASMART-TC-2K-FLOOR-PTOTECT	Subject to project needs	 WATERPROOFING PROTECTION
			 HIGH ELASTICITY

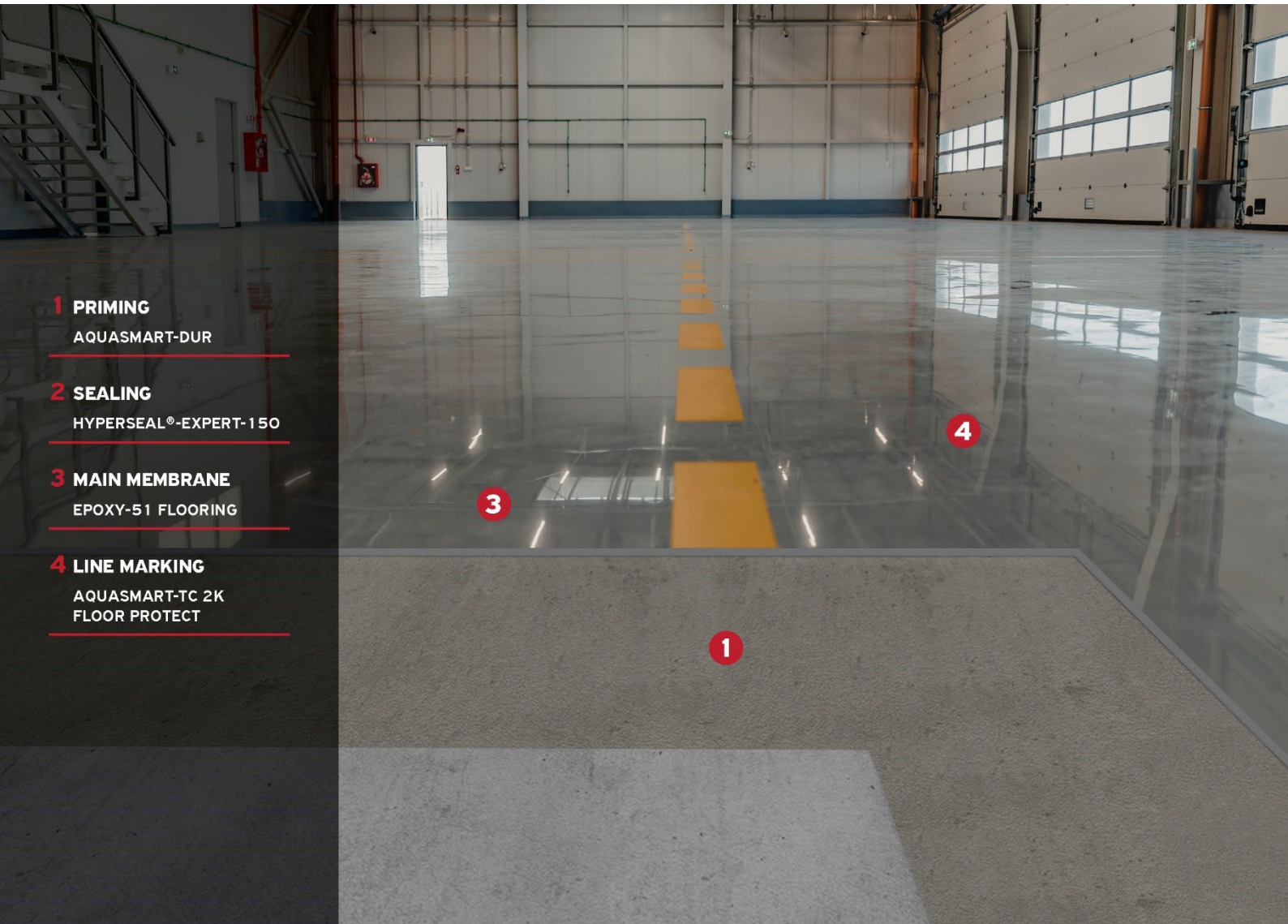



## SUBSTRATE PRIMING



PRIMER	AQUASMART-DUR / AQUADUR	AQUASMART-PU PRIMER 2K	UNIVERSAL PRIMER-2K-4060
CONSUMPTION	- 150-200 gr/m <sup>2</sup> - water/humidity barrier –three coats with total cons. of 500-600 gr/m <sup>2</sup>	- 150-200 gr/m <sup>2</sup> per coat	- 150-200 gr/m <sup>2</sup> per coat - subject to substrate porosity
COMPOSITION	WATER BASED EPOXY	WATER BASED PU	100% SOLIDS PU
APPLICATIONS METHODS	brush, roller	brush, roller	brush, roller
TACK FREE TIME, @ 77 °F (25°C) & 55% RH	3-5 Hours	1-2 Hours	1-2 Hours
RECOAT TIME OF PRODUCT WHEN NEEDED	When the material has hardened to the degree where it can no longer be punctured by fingernail 6-24 Hours	1-2 Hours	1-2 Hours
NEXT COAT TIME (HYPERDESMO® ZERO MEMBRANE)	Once the colour on the current coat goes from milky white to transparent 6-24 Hours	2-24 Hours	3-6 Hours
RECOMMENDED DILUTION	10% WATER	10% WATER	5-10% SOLVENT-O1
ADDITIVES	X	X	X
COLORS	TRANSPARENT	TRANSPARENT	TRANSPARENT
POT LIFE	1 Hour	25 min	20-30min
COMPONENTS	TWO COMPONENTS	TWO COMPONENTS	TWO COMPONENTS

Choose a suitable primer for your project needs and requirements:

■ AQUASMART-DUR is a medium viscosity epoxy-based primer. It is a water-based epoxy primer and humidity barrier, suitable for application in closed spaces too. It is a two-component product with a 1:1 mixing ratio by volume with zero VOC, low odor, and non-flammability. It has a long pot life while being fast curing, easy to clean, and suitable for concrete and humid concrete too.

*Mixing:* Mix the two components well manually or using a low speed (300 rpm) mixer.

*Application:* You choose to apply this primer over a sound concrete surface. AQUASMART-DUR primer will create a slight film sealing the concrete and increasing the adhesion. After the AQUASMART-DUR application, you should wait at least 12 hours to apply the main membrane. The main membrane application has to be done within 48 hours after the AQUASMART-DUR application. AQUASMART-DUR is completely solvent-free and low VOC primer. If a negative pressure humidity barrier is required, increase total consumption of AQUASMART-DUR at a minimum of 500 gr/m<sup>2</sup> in 3 successive layers (150-200gr/m<sup>2</sup> per coat)

■ AQUASMART®-PU PRIMER 2K is a revolutionary polyurethane water-based primer. It is a 100% polyurethane product that can be applied on damp concrete, making it an ideal same-day primer. The product is solvent-free and zero VOC, making it suitable for both indoor and outdoor use. This two-component, 1:1 volume product is fast curing, low-odor, safe, non-flammable, and non-IMO, suitable for closed spaces. It has a long pot life, easy clean-up, and strong adhesion, even on damp or green concrete. It can be used on concrete, humid concrete, metal/steel, aluminum, glass, and wood and can be applied with brush, roller, or airless spraying. The product is recommended for use as a primer for HYPERDESMO® and AQUASMART® based products and for difficult main coat applications like POLYUREA-based materials.

*Mixing:* Mix the two components well manually or using a low speed (300 rpm) mixer.

*Application:* You choose this primer when the application temperature is below 15°C and when you need a fast-curing primer that will allow same day application. Apply with roller in one or two thin coats with total consumption of 150 gr/m<sup>2</sup>. Following application of AQUASMART-PU PRIMER 2K, the main membrane may be applied within 2-24 hours.

■ UNIVERSAL PRIMER-2K-4060 is a fast-curing polyurethane primer that allows same-day application for both primer and main coat membrane. It is ideal for cold weather or low humidity conditions, as its curing time is not significantly affected by climate making it suitable for use in cold climates or low humidity conditions. The 100% polyurethane product can be applied on damp concrete and performs excellent adhesion to various surfaces (exceeding the requirements of EOTA). It is non-toxic and has zero VOC. The product is an excellent bitumen-oil barrier and is solvent-less, making it suitable for closed spaces.

*Mixing:* Mix the two components well manually or using a low speed (300 rpm) mixer. Mix the two components well. In high temperatures, pour mixture in shallow, wide container in order to increase pot life.

*Application:* You choose this primer when you need an effective oil barrier and a fast curing, solventless PU primer. UNIVERSAL PRIMER-2K-4060 is an ideal solution when working over old concrete surfaces contaminated by oils, grease etc., because it creates a very effective “oil barrier” film that protects the new coating. UNIVERSAL PRIMER-2K-4060 is solvent free and zero VOC primer and suitable for both indoors

and outdoors applications. Apply with brush or roller in thin coat with total consumption not exceeding 200 gr/m<sup>2</sup>. In order to achieve such a small consumption, you can dilute UNIVERSAL PRIMER-2K-4060 with 5-10% of SOLVENT-01 (After thinning the product no longer has zero VOC). Main coat must be applied maximum 6 hours after primer application.

*Tip:* For increased pot life and/or reduced consumption, add 5-10%. Empty mixed pail contents either in a shallow container or directly on the surface to be primed in order to increase the pot life further.



*Notes:*

1. If it rains after the primer and before the main coat application, you may need to apply one coat of primer again.
2. More primers are available for special cases, surfaces, and weather conditions.
3. For more information about surface preparation please contact our technical assistance team.

## DILATATION JOINTS, INNER ANGLES & SMALL CRACKS

Concrete expansion joints are small gaps in structures designed to prevent cracks, absorb stresses, and allow soil movement. They allow independent movement and thermal expansion without inducing stress. Concrete is susceptible to cracks due to its non-elastic nature, so joints are strategically placed to prevent failure. However, structures with expansion joints are susceptible to water leaks, so waterproofing and applying a durable sealant are essential to maintain flexibility and allow the joint to

function properly. All dilatation joints, inner angles, wall-floor connections, cracks, drainage details, pipes, and other elements of equipment mechanically installed must be treated.

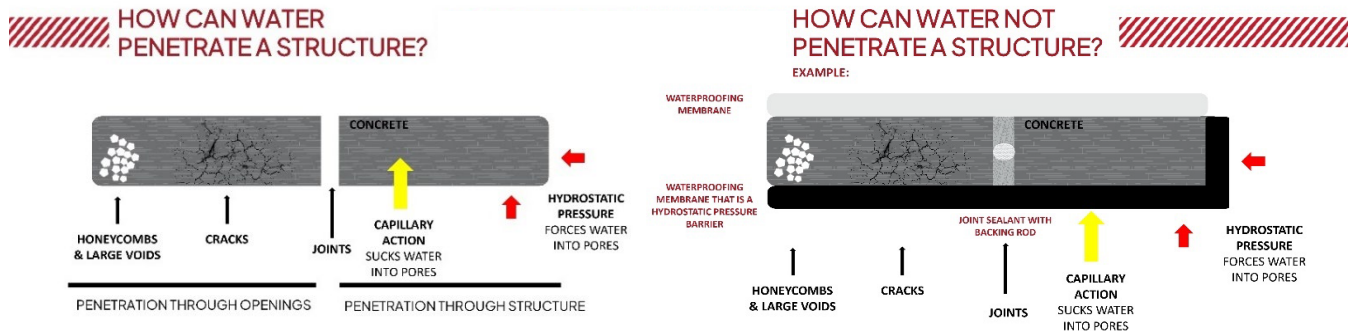

Dilatation joints and inner angles should be treated with HYPERSEAL®-EXPERT-150 or HYPERSEAL®-EXPERT-60FC, polyurethane based sealants.

Clean joints thoroughly, and ensure that no dust, oil, grease, wax contaminants, or silicone remains are present. For many applications, primer is not obligatory. However, in case of application on porous or/and wet substrate the primer is required, as there is a possibility of air bubbles blown into the uncured sealant if the substrate temperature rises.



- On concrete: pieces of 25-50m<sup>2</sup>
- On Screed: pieces of 15-25m<sup>2</sup>
- Over the junction points where the horizontal surface meets the vertical

After the primer is cured, apply in dilatation joints the right backing material (where needed) – an open cell polyurethane or a closed cell polyethylene backing rod. Be sure that when applying a closed cell polyethylene backing rod, its outer skin is not punctured, as rising temperature may cause bubbles. Backing rod application is important as it ensures the correct width-to-depth ratio and provides a firm backing against which the sealant can be tooled off. Apply the sealant HYPERSEAL®-EXPERT-150 or HYPERSEAL®-EXPERT-60FC.



■ HYPERSEAL®-EXPERT-150 is a low modulus sealant, formulated to ensure bubble free cure even at very high temperatures and humidity climatic conditions. The product displays excellent thixotropy allowing its use even in very large expansion joints. It cures by reaction with atmospheric humidity to produce a joint sealant with a 50% joint movement accommodation factor and excellent adhesion on many types of substrates (concrete, fibrous cement, mosaic, cement roof tiles, wood, also glass, aluminum, steel, polycarbonate, etc.). The extrusion rate and tooling of the sealant remain the same throughout a very wide range of temperature and humidity conditions.

■ HYPERSEAL®-EXPERT-60FC is a high-performance sealant engineered to deliver exceptional sealing capabilities in diverse environments. This product is specially designed for fast curing and low modulus, making it ideal for applications requiring rapid turnaround without sacrificing quality. The sealant excels in bubble-free curing, even under extreme conditions of temperature and humidity, ensuring a consistent application every time. HYPERSEAL®-EXPERT-60FC reacts with atmospheric humidity to form a durable seal with a 60% joint movement accommodation factor, adhering superbly to a variety of substrates including concrete, aluminum, glass, and polymers. It maintains excellent extrusion rate and ease of tooling across a broad spectrum of climatic conditions, demonstrating its versatility in both indoor and outdoor settings.

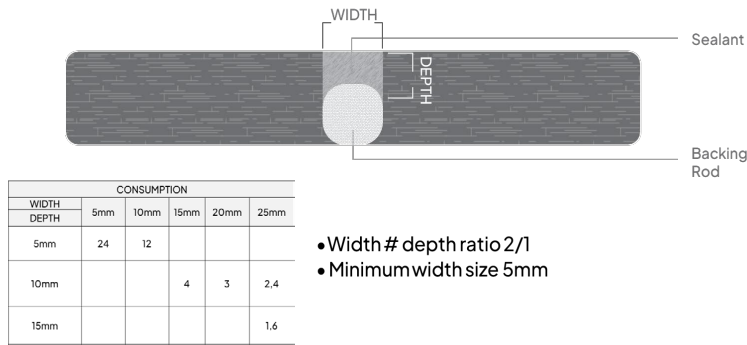

HYPERSEAL®-EXPERT-150 is particularly effective in high humidity and temperature conditions, offering a 50% joint movement accommodation factor and excellent adhesion to a variety of substrates.

HYPERSEAL®-EXPERT-60FC, known for its rapid curing and low modulus, is ideal for fast-paced projects requiring durable and reliable sealing under extreme environmental conditions. Both sealants ensure consistent performance and adaptability across a wide range of climatic conditions, making them ideal for metal roofing applications.

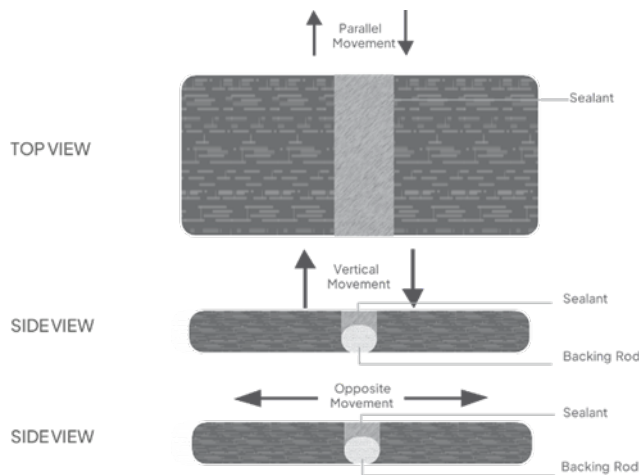

Slide the sealant HYPERSEAL®-EXPERT-150 or HYPERSEAL®-EXPERT-60FC into the sealant dispensing gun, cut off the very end of the sealant packaging, and fit the gun with the nozzle. The nozzle should be cut to deliver the right bead size. Extrude the sealant into the joint ensuring that no air is trapped in the

joint. Tooling is recommended immediately after the application of sealant. The ratio width to depth should be 2:1 subject to a maximum depth of 25mm.

#### NOTE:

- Tool the sealant with a spatula.
- Do not use any solvent, alcohol, or soap to smooth the material.
- Clean tools and equipment first with a paper towel and then using SOLVENT-01.

#### POLYETHYLENE BACKER ROD

Special backer rod made of extruded polyethylene for joints where HYPERSEAL® sealants will be used.



SIZE	PACKAGING
F6	1500m
F10	680m
F15	250m
F20	180m
F25	100m
F30	100m
F40	100TEM
F50	65TEM

## MAIN FLOORING COAT

EPOXY RESIN 51 FLOORING is a high-performance, two-component, self-leveling, solvent-free epoxy-based floor coating designed for applications requiring durable and chemical-resistant surfaces. Its excellent mechanical properties make it suitable for high-traffic areas and environments exposed to chemical spillage. This resin is solvent-free, ensuring no harmful emissions and making it safer for indoor applications. It offers high impact and abrasion resistance, providing long-lasting durability

EPOXY RESIN-51-FLOORING	
CONSUMPTION	Minimum: 2 kg/m <sup>2</sup>
APPLICATIONS METHODS	brush, roller, spatula, notched trowel
APPLICATION OVER PREVIOUS COAT (PRIMER)	Depending on the primer curing time
RECOAT TIME OF PRODUCT	6-24 Hours
NEXT COAT TIME (TOPCOAT)	6-24 Hours
LIGHT TRAFFIC	24 Hours
HEAVY TRAFFIC	7 DAYS
COLORS	GREY, NEUTRAL
COMPONENTS	TWO COMPONENTS

even under heavy traffic conditions. The chemical resistance of EPOXY RESIN 51 FLOORING is effective against acids, solvents, and lubricants, making it ideal for industrial and commercial environments. Additionally, it inhibits fungal and bacterial growth, which is essential for healthcare and food industries. This versatile resin is used in various settings, including industrial floors, hospitals, pharmaceutical facilities, food processing areas, indoor car parks, retail shopping areas, and hotels.

**Mixing:** Use a low speed (300rpm) electric drill. Before mixing component A+B, mix component A thoroughly. Pour Component B into Component A pail and mix using a low speed (300 rpm) electric drill until mixture is completely homogenous. Pay particular attention to the wall lining and bottom of the pail.

**Application- Thickness:** For higher film thickness build up, dry silica sand may be added up to 1:1 by weight. Consumption determination depends primarily on final intended use of the floor. Traffic resistance is improved with higher consumption. In order to calculate dry film thickness, note that 2kg/m<sup>2</sup> of EPOXY RESIN-51 FLOORING will give you around 1.1mm. After application and levelling of EPOXY-RESIN-51-FLOORING, the surface is treated with a spike roller to remove air bubbles and to give a final smooth film finish.

**Potlife:** >40 minutes @ 25 °C & 55% RH.

**Tip:** EPOXY-RESIN-51-FLOORING will discolor when exposed to UV. For color protection, traffic/abrasion resistance as well as providing an easy cleaning the use of an additional pigmented Top Coat is recommended.

## TYPES OF APPLICATIONS

## APPLICATION

- *Application As Paint:*  
Apply EPOXY RESIN 51-FLOORING A+B without addition of quartz sand with a roller or spatula in two coats with 0.250-0.350 Kg/m<sup>2</sup> per coat (minimum total consumption 0.5 Kg/m<sup>2</sup>). To make an anti-slip finish the final layer is broadcasted with silica sand or corundum.
- *Application As Self-Leveling:*  
To the mixture of EPOXY RESIN 51-FLOORING A+B, add 1:1 by weight dry silica sand 0.1-0.3 diameter. Pour the material on the floor and apply by 5mm notched trowel. Use a spiked roller to subsequently remove entrapped air.

PIGMENTATION OF EPOXY  
RESIN-51-FLOORING NEUTRAL

EPOXY RESIN-51-FLOORING is either pre-pigmented from the factory in grey colour or it comes in NEUTRAL version that must be pigmented with ALCHIMICA's PIGMENT PASTES only (10% max).

At a maximum ratio of 10% by weight, the PIGMENTS PASTES are designed to be compatible with ALCHIMICA's products, offering high hiding power to the neutral version of HYPERFLOOR-2K. Pour the PIGMENT PASTE content of the pail into the product at a maximum ratio of 10% by weight. Mix thoroughly using a low-speed electric mixer until the product homogenizes. Apply the product as per standard application instructions.

APPLICATION WITH SILICA  
SAND BROADCASTING

If an anti-slippery effect is required, silica sand or corundum aggregates can be broadcasted over the topcoat that is used in order to protect the EPOXY RESIN-51-FLOORING flooring membrane.

Apply the first coat of HYPERDESMO®-ADY-E (PIGMENTED)/-ADY-810 at consumption of 0.3 kg/m<sup>2</sup> over the well-cured HYPERFLOOR-2K surface.

Broadcast natural dry quartz or corundum aggregates over the fresh first layer of HYPERDESMO®-ADY-E (PIGMENTED)/-ADY-810. The next day you remove the excess non-bonded aggregates. Most applicators use a vacuum cleaner.

Then, you apply on top a second thin coat of HYPERDESMO®-ADY-E (pigmented or transparent)/ ADY-810 at 200-300 gr/m<sup>2</sup> in order to encapsulate the silica sand.

## TRAFFIC LINE MARKING

To protect floor substrates from stains and tire marks, particularly in industrial spaces, specific products and application procedures are recommended. One such product is **AQUASMART-TC-FLOOR PROTECT**, which is effective in shielding the flooring system from tire marks and stains. Traffic lines should be applied using **AQUASMART-TC 2K FLOOR PROTECT**, pigmented to the desired color, within 48 hours after the final coat. This coating is versatile and can be easily pigmented with various water-based color pastes.

AQUASMART-TC 2k FLOOR PROTECT	
CONSUMPTION	0.150 kg/m <sup>2</sup> per coat In Total: 0.3kg/m <sup>2</sup> in two or more coats.
APPLICATIONS METHODS	brush, roller, airless spraying
TACK FREE TIME, @ 77 °F (25°C) & 55% RH	-
APPLICATION OVER PREVIOUS COAT	It must be applied WITHIN 24-72 hours, depending on weather conditions.
RECOAT TIME OF THE PRODUCT	When completely dry
POT LIFE	-
COLORS	TRANSPARENT
COMPONENTS	TWO COMPONENTS

The application process involves using a roller to apply the product at a total consumption of 0.15-0.30 kg/m<sup>2</sup> in one or two coats. Light pedestrian traffic is permissible after 24 hours, while vehicle traffic should be allowed only after 5 days from the final layer application.

**AQUASMART® -TC 2K FLOOR PROTECT** is a two-component, water-based, aliphatic coating renowned for its exceptional performance in a multitude of applications. It is highly recommended as a top coat for protecting epoxy and polyurethane self-leveling floors, thanks to its excellent UV, chemical, water, and abrasion resistance. This product also offers superior resistance to staining and can be easily pigmented with off-the-shelf water-based pigment pastes in a 5-10% by weight ratio, depending on the required hiding power.

This product is particularly suitable as a UV protective (pigmented) top coat for self-leveling polyurethane and epoxy floors, serving as a final protective layer for car parks, and for industrial paint applications. Its features and benefits include being water-

based, easy to apply, fast curing, and having excellent UV resistance. Additionally, it can be easily pigmented with water-based pigment concentrates, has a long pot life, and provides excellent interlayer adhesion.

By using AQUASMART® –TC 2K FLOOR PROTECT as a top coat, floors can be effectively shielded from the staining effects of tire oils and chemicals, ensuring both longevity and aesthetic appeal.

*Mixing:* Use a low speed (300 rpm) mixer. Add the second component and continue mixing for a few minutes. Add the pigment paste 5-10% by weight and mix until product has a homogenous color.

*Application:* Application of AQUASMART®-TC 2K FLOOR PROTECT is straightforward and user-friendly. It is straightforward: mix the two components with a low-speed mixer until a homogenous color is achieved. It can be pigmented with water-based pastes and applied with a roller or spray at a rate of 150-300 grams per square meter in one or two coats. Ensure the first coat is dry before applying the second to avoid defects.

*Disclaimer:* Make sure not to disturb applied material with excessive rolling as roll marks may appear. The material is relatively fast drying and therefore any additional rolling after the first application will cause surface defects to appear. Make sure the first coat is completely dry before second coat is applied.

#### TYPES OF APPLICATIONS

APPLICATION BY COATS	Per coat: 0.150 kg/m <sup>2</sup> . Apply more coats depending on project requirements and system build-up.
PIGMENTATION OF AQUASMART-TC-2K-FLOOR PROTECT	The material is easily pigmented by using water-based pigment pastes. At a maximum ratio of 10% by weight, the water-based pigments offer high hiding power to the transparent or white versions of the product. Pour the PIGMENT content of the pail into the product at a maximum ratio of 10% by weight. Mix thoroughly using a low-speed electric mixer until the product homogenizes. Apply the product as per standard application instructions.
APPLICATION WITH AIRLESS (200- 250 bar) SPRAY MACHINE.	<ol style="list-style-type: none"> <li>1. Open the pail and stir it up to homogenize. Stirring can either be done manually or with a low speed (300 rpm) mixer.</li> <li>2. If necessary, add up to 5% water into the pail and mix it with low-speed mechanical equipment or by hand.</li> <li>3. Apply thin layers using an airless spray machine.</li> <li>4. Wait for the recoat time.</li> <li>5. Repeat this process until the desired or recommended thickness.</li> </ol>

## CARVING AND TREATING NEW DILATATION JOINTS

After the full cure of EPOXY RESIN-51 FLOORING, dilatation joints need to be carved on the floor. Joints frequency, width and depth should be deemed by the contractors and engineers, depending on the room's geometry. New dilatation joints should be treated with HYPERSEAL-EXPERT-150, following a width/depth ratio of 2/1.



## CLEANING

Clean tools and equipment first with paper towels. Tools and equipment should be cleaned immediately using SOLVENT-01 (or water for water-based materials). Rollers will not be re-usable.

## MAINTENANCE

- a. Surfaces may be cleaned with commercial detergents. ALCHIMICA recommends that a maintenance service contract be established between the project owner and the applicator.
- b. Regular inspection and repair of damaged surfaces will considerably prolong the performance and the expected life of the waterproofing system.
- c. Portions of the membrane that exhibit wear are considered an item of maintenance and not an item of warranty.
- d. All sharp debris such as gravel, sand and metal should be removed on a regular basis to avoid damage to the coating.
- e. When removing snow, avoid the use of metal blades or buckets that could damage the coating.

## REFERENCES

ALCHIMICA, throughout the years, has a collection of completed projects from around the world. On our website, you can find where we have provided a variety of solutions and expert know-how, in case studies ranging from the smallest roof to the largest project. [www.alchimica.com](http://www.alchimica.com)



## HEALTH AND SAFETY

The system proposal contains volatile flammable solvents. Apply in well-ventilated, no-smoking areas, away from naked flames. In closed spaces use ventilators and carbon-active masks. Keep in mind that solvents are heavier than air, so they float near the floor. The MSDS (Material Safety Data Sheet) of the products are available on request.

This handling safety advice is required for the implementation procedure as well as in the pre- and post-exposure to the loading machinery.

- Protect your lungs by using an air-purifying respirator when handling or spraying.
- Use rubber gloves to protect your skin and remove them promptly after contamination. Wear clean undergarments. After work and before eating, drinking, or smoking, thoroughly wash your hands with soap and water.
- Wear safety goggles to protect your eyes and face from splashes and airborne particles.
- Waste generation should be avoided or reduced.
- Incinerate under well-controlled conditions in line with local and national rules and regulations.
- Re-occupancy of the work site without respiratory equipment is limited to 24 hours if proper ventilation for the sprayed area is provided.
- Contractors and applicators must follow all applicable and necessary storage and safety regulations.
- In any case, review the system's material and safety data sheets.

## PRECAUTIONS AND VARIATIONS.

The purchaser must determine the suitability of the products for the intended use and assume all related liabilities and risks. This information, recommendations, and any additional technical advice are given in good faith and are based on ALCHIMICA's present knowledge and experience of the products when properly stored, handled, and applied under normal conditions according to ALCHIMICA's recommendations.

However, ALCHIMICA assumes no liability for providing such information and advice including the extent to which such information and advice may relate to existing third-party intellectual property rights, especially patent rights, nor shall any legal relationship be created by or arise from the provision of such information and advice. ALCHIMICA reserves the right to change at any time the properties of its products. The purchaser of the product(s) must test the product(s) suitability for the intended application and purpose before proceeding with a full application of the product(s).

The performance of the products build up described herein should be verified by testing and carried out by qualified experts.

NOTE: This method statement is offered by ALCHIMICA as a 'summary proposal' for **POLYURETHANE FLOORING SYSTEM BASED ON HYPERFLOOR-2K**. For projects' particularities and more precise technical support, please contact ALCHIMICA at: [alchimica@alchimica.com](mailto:alchimica@alchimica.com)

Please consult the above-referred products' technical data sheets (TDS) and safety data sheets (SDS). Under any circumstances, ALCHIMICA does not assume any responsibility for the performance of the waterproofing system given the conceptual flaws of the existing build-up. Imperative for the performance of the system is the correct cleaning, inspection, and maintenance of the waterproofing system. For projects' particularities and more precise technical support, please contact ALCHIMICA at: [alchimica@alchimica.com](mailto:alchimica@alchimica.com)

Where alternative systems are to be used, these must be submitted to ALCHIMICA for approval. ALCHIMICA will not accept responsibility or liability for variations to the above under any other condition.

## LEGAL NOTES AND CITATION

- This is a technical document, without legal value.

- No liability or warranty of product performance is created by this document.
- All the information included is collected from materials TDS, DoP, and certificates available at the moment of publishing.
- ALCHIMICA S.A. does not guarantee the accuracy of its instructions or specifications, nor do we assume any responsibility for damages resulting from the use or reference of the information provided. The company reserves the right to change the properties of its products at any time, and the current version of the technical data sheet is available on the website [www.alchimica.com/en](http://www.alchimica.com/en)
- Appropriate Technical Documentation and/or Specific Technical Documentation: The performance of the products identified in the DoP files conform with the set of declared performances. This declaration of performance is issued in accordance with Regulation (EU) No 305/2011, under the sole responsibility of the manufacturer.
- It is recommended to check the TDS and MSDS of all the materials before use and application.
- The use of these materials and products is beyond the scope and control of ALCHIMICA.
- Proper application is the responsibility of the Buyer and/or Contractor.
- It is forbidden to reproduce it in any form, totally or partially.
- All the above written and provided is subject to the terms and conditions of sale and marketing of ALCHIMICA S.A.

ALCHIMICA S.A.

7, Lampsakou Str.

115 28, Athens Greece

Tel.: +30 214 4167 700

Fax: +30 214 4167 701

[www.alchimica.com](http://www.alchimica.com)