

INDOOR CAR PARK SOLUTION BASED ON HYPERFLOOR®-2K.



TABLE OF CONTENTS

TABLE OF CONTENTS.....	2
WHY CHOOSE ALCHIMICA in car park WATERPROOFING PROJECTS?.....	4
WHY CHOOSE SAME-DAY WATERPROOFING APPLICATIONS - EXPLAINING THE HAA TECHNOLOGY.....	Error! Bookmark not defined.
Additional products with HAA technology.	Error! Bookmark not defined.
ALCHIMICA’S POLYURETHANE LIQUID MEMBRANES	9
Exposed Car Park Systems.....	Error! Bookmark not defined.
ALCHIMICA'S SOLUTIONS FOR EXPOSED CAR PARK WATERPROOFING.....	Error! Bookmark not defined.
COOL ROOFS: ENHANCING URBAN ENERGY EFFICIENCY IN BUILDINGS THROUGH HEAT ISLAND REDUCTION	Error! Bookmark not defined.
COOL ROOF	Error! Bookmark not defined.
PREPARATION.....	15
REPAIR and LEVELING MORTARS	16
REPAIRING.....	16
LEVELING.....	17
PRIMER SELECTION	17
SEALING SOLUTIONS	18
REINFORCEMENT OF WATERPROOFING MEMBRANES WITH GEOTEXTILE	19
METHOD STATEMENT	21
GENERAL SYSTEM CONDITIONS	21
SYSTEM PRODUCTS BUILD-UP	24
SUBSTRATE PRIMING	26
DILATATION JOINTS, INNER ANGLES & SMALL CRACKS	28
TREATMENT OF DETAILS	31
MAIN WATERPROOFING MEMBRANE.....	Error! Bookmark not defined.
TRAFFIC TOP COAT.....	Error! Bookmark not defined.

TRAFFIC LINE MARKING.....	37
CLEANING.....	39
ADDITIVES FOR THE HYPERDESMO® MEMBRANES	Error! Bookmark not defined.
REPAIR, OVERLAPS PROCESSES.....	40
REFERENCES	41
HEALTH AND SAFETY.....	42
PRECAUTIONS AND VARIATIONS.	42
LEGAL NOTES AND CITATION	42

WHY CHOOSE ALCHIMICA IN CAR PARK WATERPROOFING PROJECTS?

Car parks, also known as parking garages, parking structures, or parking decks, are essential in urban areas, offering vital parking solutions for commuters, businesses, and residents. These structures, ranging from small open-air lots to expansive multi-level facilities, face constant vehicular traffic, varying weather conditions, and potential chemical spills. To ensure their durability, safety, and functionality, robust waterproofing and flooring systems are crucial.



Waterproofing concrete surfaces in structures like car parks is vital due to the porous nature of concrete and its susceptibility to water damage. Without proper waterproofing, water infiltration can lead to structural deterioration, particularly in

reinforced concrete where steel reinforcement is embedded within the concrete matrix. Waterproofing acts as a protective barrier, preventing water penetration and preserving the concrete's integrity. This process extends the structure's lifespan by shielding it from water-induced harm, such as corrosion of reinforcing steel and freeze-thaw cycles. Additionally, waterproofing prevents mold and mildew growth, which pose health risks and further structural issues. By inhibiting these developments, waterproofing contributes to a healthier indoor environment. Furthermore, it enhances energy efficiency by preserving insulation properties and reducing energy consumption for heating and cooling. Though the initial investment in waterproofing may seem significant, it proves cost-effective in the long run compared to repairing water damage. Proactively addressing waterproofing can prevent costly repairs and replacements, making it a prudent long-term strategy. Compliance with building codes and regulations is also essential for ensuring structural safety and longevity.

In car parks, the need for effective waterproofing and flooring systems is amplified by the various stresses they endure. Constant vehicular movement causes significant surface wear, necessitating high abrasion resistance. Car parks are exposed to

automotive fluids like oil, brake fluids, and antifreeze, which can degrade unprotected surfaces. For exposed car parks, weather elements such as rain, snow, and sunlight can cause substantial damage, making UV resistance and tolerance to temperature variations crucial. Slip resistance is vital to ensure the safety of both pedestrians and vehicles, especially in wet conditions. Minimizing tire noise enhances the user experience, particularly in indoor car parks where noise can echo and amplify.

Car parks can be categorized into exposed and non-exposed systems, each with specific requirements. Exposed car parks, open to the elements, must withstand various weather conditions and therefore require waterproofing to prevent water ingress, UV resistance to guard against sunlight degradation, temperature variation tolerance to handle significant changes without cracking, and mechanical strength to endure vehicle loads and stress. Non-exposed car parks, typically enclosed or underground, are protected from direct weather exposure but still require abrasion and chemical resistance to withstand wear and tear from vehicles and exposure to automotive fluids. They also need slip resistance for safety in wet conditions and noise reduction to enhance the user experience by minimizing tire noise within enclosed spaces. Despite their different requirements, both types serve the same fundamental purpose: providing a safe, durable, and functional space for vehicle storage.

Alchimica provides advanced solutions for car park waterproofing and flooring, addressing the specific needs of both exposed and non-exposed car parks. Our comprehensive and tailored solutions include high UV resistance and temperature variation tolerance for exposed car parks, and superior abrasion and chemical resistance for non-exposed car parks, ensuring long-lasting protection against heavy traffic and chemical exposure. Alchimica's products like HYPERDESMO® polyurethane coatings offer exceptional mechanical properties, including high tensile and tear strength, ensuring that the car park surface can handle heavy loads and stresses without compromising integrity. Our solvent-free polyurethane flooring systems provide high chemical resistance, protecting against spillages from oil and brake fluids, and acting as a waterproofing shield.

Alchimica offers both solvent-based and solvent-free product options. Our systems, including the solvent-free options, are designed to be safe for applicators. This is particularly important for indoor applications where air quality must be maintained. Our solutions are designed to offer high performance while minimizing environmental impact. Alchimica's waterproofing systems are built to last. Our products provide high elasticity and crack-bridging capacity, preventing water ingress and protecting the structure from deterioration. The durability of our coatings ensures long-term protection, reducing the need for frequent maintenance and repairs. Alchimica's systems also allow for the application of vibrant, durable traffic markings, enhancing the visual appeal and functionality of the car park. Our products are available in various colors, helping in the organization and navigation within the car park, making it easier for users to locate their vehicles.

With extensive global experience in waterproofing and sealing car park areas, Alchimica provides comprehensive support at every project phase. Our expertise ensures that specific project requirements are met with precision and efficiency. From surface preparation to the application of primers, sealants, main coats, and top coats, Alchimica's team offers technical assistance to ensure a successful and lasting installation. High solar reflectance coatings used in Alchimica's systems help in keeping exposed car park surfaces cooler, contributing to energy efficiency. This reduces the heat island effect and lowers cooling costs for the building, providing an eco-friendly solution.

Car parks, whether exposed or non-exposed, require robust waterproofing and flooring systems to ensure their safety, durability, and functionality. Alchimica's advanced solutions cater to these needs with high-performance products designed to withstand mechanical stresses, chemical exposure, UV radiation, and temperature variations. Our comprehensive, aesthetically pleasing systems offer long-term protection and durability, making them an ideal choice for any car park waterproofing project. With Alchimica's global expertise and support, you can be assured of a high-quality, reliable solution that meets all the demands of modern car park systems.



Liquid-applied membranes offer ease of application and installation, taking the shape of the structure, piercing through pores and cracks, filling voids, and resulting in a seamless elastic membrane. These membranes continue waterproofing even after minor seismic

activity, have self-leveling properties, and offer versatile installation alternatives. They are a cost-effective investment compared to repairing water damage and removing sheets and roll membranes. Flat roofs with poor construction and design often face ponding water, where water remains on a roof surface longer than 48 hours after the last rain event, leading to long-term water leakage and costly repairs. Liquid-applied waterproofing systems can prevent these problems and are beneficial for post-repair actions. These membranes with high ponding water resistance can bond with the substrate, providing protection against puddles formed due to poor slope design. To test the adhesion of the existing membrane, it should be pressed on the ponding areas. Without proper ponding water resistance properties, a waterproofing membrane can start blistering and peeling, leading to roof system deterioration. HYPERDESMO® waterproofing membranes offer excellent water resistance, with zero water swelling rate, high UV, chemical, and mechanical resistance, and protection against harsh environmental conditions.



Alchimica is a pioneer and a global leader in complete polyurethane waterproofing solutions. With pedigree and expertise in this field, Alchimica overcomes the challenges that others deem impossible. The technological depth and know-how of Alchimica allow the formulation of innovative PU-based materials that can achieve performance levels that are not typically met. Alchimica has been active in the research, development, and production of building chemicals for 42 years, providing solutions for liquid waterproofing, reparations, sealing, flooring, and ETICs. The know-how of Alchimica in Research and Development laboratories in construction,

repair, and renovation solutions of buildings and infrastructure meets international industry standards.

ALCHIMICA'S POLYURETHANE LIQUID MEMBRANES

To ensure effective waterproofing, it is crucial to select PU membranes that meet specific criteria: impermeability, flexibility, durability, breathability, and resistance to environmental factors such as UV radiation, heat, humidity, and chemical exposure.

ALCHIMICA is a leader in the waterproofing industry, pioneering the use of liquid applied polyurethane membranes. With a commitment to high performance and durability, ALCHIMICA's products excel in applications where seamless systems are paramount, whether for structural integrity or aesthetic appeal. These membranes offer decisive advantages, particularly in complex scenarios like geometrically complicated connections with ventilation outlets or upturns.

Throughout its history, ALCHIMICA has continuously expanded its range of polyurethane liquid membranes to provide versatile installation alternatives and long-lasting solutions. From one and two-component polyurethane liquid membranes to bitumen-extended polyurethanes, water-based liquid polyurethane membranes, and advanced technology polyurethane dispersion (PUD) products, each solution is meticulously designed to address a wide array of waterproofing challenges with optimal performance and durability.

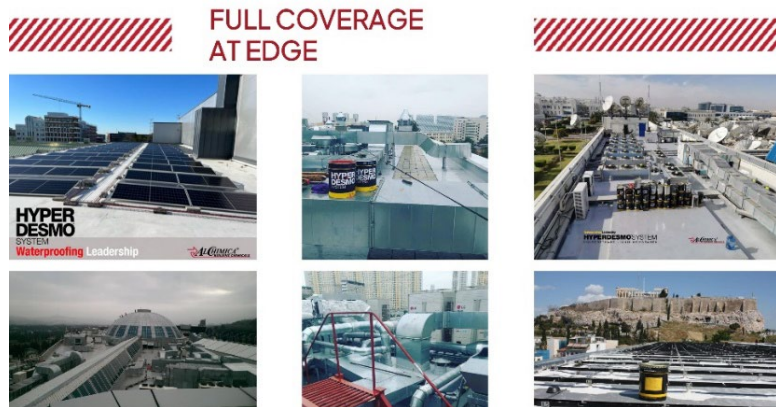

ALCHIMICA's liquid membranes offer durability upon application, elasticity to withstand various stresses and traffic, and resistance to chemicals, and ponding water.

These properties meet stringent technical specifications, making them suitable for a diverse range of applications. The core objective of ALCHIMICA is to develop waterproofing systems that are competitive, simple to apply, and accessible to all professionals. By prioritizing ease of application and reliability, ALCHIMICA empowers users to achieve effective waterproofing solutions efficiently and effectively. The membranes are seamless, durable, and flexible and provide superior waterproofing performance, waterproof and moisture permeable, preventing water penetration, allowing moisture to escape, and reducing the risk of degradation and

failure over time. With mechanical, thermal, and chemical resistance properties and breathability, ALCHIMICA's PU membranes ensure the longevity and efficiency of waterproofing systems.

ALCHIMICA's commitment to innovation and excellence has revolutionized waterproofing technologies globally. With a comprehensive range of polyurethane liquid membranes tailored to meet the demands of modern construction projects, ALCHIMICA remains the premier choice for effective, long-lasting waterproofing solutions.

THE IMPACT OF SOLVENTLESS WATERPROOFING SOLUTIONS



The construction and infrastructure industry is increasingly focusing on reducing its environmental footprint, leading to the more frequent use of solventless polyurethane liquid membranes as a sustainable alternative to traditional solvent-based waterproofing solutions. These solventless technology products not only protect structures from water but also safeguard health and the environment. The application procedure of solventless polyurethane systems is straightforward and can be performed with a spray, roller, or brush, making them highly attractive for various projects.

Technological advancements have made solventless options more viable, as they maintain or even exceed the performance of traditional methods without the environmental and health risks associated with VOCs. Solventless polyurethane membranes significantly reduce harmful emissions, contributing to lower air pollution levels. This aligns with global efforts to combat the climate crisis. The health and safety benefits of using solventless options are also significant, creating a safer workplace and living environment. This parameter is extremely important in applications in closed areas, indoor spaces, and areas without good ventilation, where the impact of VOCs would be most detrimental.



The performance and durability of solventless products are impressive, offering excellent elasticity, resistance to weather, chemicals, and extreme temperatures. Choosing sustainable waterproofing solutions that do not contain volatile organic compounds (VOCs) provides numerous advantages, such as compliance with strict environmental regulations, long-term cost savings, and the ability to qualify projects for green building certifications.

The transition towards solventless polyurethane liquid membranes marks a significant step forward in the waterproofing industry, offering a promising path to effectively protect buildings from water damage while significantly reducing environmental impact and health risks associated with traditional methods. As technology continues to advance, solventless and zero VOC solutions are expected to play an increasingly central role in sustainable construction practices. The choice of solventless waterproofing products is driven by a combination of environmental stewardship, health and safety considerations, and the technical demands of specific projects. These products are especially suited to applications where the well-being of occupants, workers, and the natural environment is a priority, alongside the need for durable, effective waterproofing performance.

Alchimica offers 100% solids, solventless solutions such as HYPERDESMO®-D-2K, HYPERDESMO®-ZERO, and other innovative products. The development of HYPERDESMO® ZERO technology represents a significant stride towards meeting and surpassing contemporary standards of the eco-industry, demonstrating a commitment to innovation that serves the planet and its inhabitants. The adoption of solventless waterproofing solutions like HYPERDESMO® ZERO is not just a matter of environmental or health compliance; it is a strategic decision aligned with global sustainability goals.

INDOOR CAR PARK SYSTEMS

The use of indoor car parks, especially in large cities, makes the life of commuters easier as parking space is limited. Moreover, in busy urban environments, indoor car parks are designed with colorful indicators using eye-catching colours to help us find our cars. However, because of the demanding vehicular traffic, indoor car parks require coatings that can withstand high mechanical stresses caused by traffic, as well

as systems that offer high abrasion and slip resistance. ALCHIMICA's seamless solvent-free polyurethane flooring car park system can be applied to every indoor car park project. This system offers high chemical resistance and provides protection against spillages from oil and brake fluids while also acting as a waterproofing shield. Our proven and competitive solutions are designed to support any project with high performance conditions, offering elasticity, durability, protection, and long-term service life.

Liquid-applied waterproofing systems for indoor car parks typically consist of several layers, each serving a specific purpose to ensure the overall effectiveness and durability of the system. This general overview highlights the key layers, but specific systems can vary depending on regulations, products, conditions, and company practices. Generally, these layers include:

- **Primer:** The first step is the application of a primer, which prepares the substrate and ensures proper adhesion of subsequent layers. The selection of the primer depends on the substrate type and porosity.
- **Waterproofing Membrane:** After priming, the waterproofing layer is applied. This can be achieved using various systems like polyurethane coatings, which offer versatility and can be applied using rollers, brushes, or airless spray.
- **Top Coat with Sand:** A top coat broadcasted with sand is applied next. This layer builds up the system's thickness, enhances durability, and creates an anti-slip surface. The sand is broadcast into the wet top coat to ensure proper adhesion and desired texture.
- **Top Coat for Sand Encapsulation:** An additional top coat is applied to encapsulate the sand, locking it in place. This top coat does not need to be aliphatic to provide UV resistance, as the system is indoor and not exposed to UV rays. It offers exceptional abrasion and scratch resistance, suitable for heavy-duty, high-traffic areas.

Traffic Line Marking: The final step is the application of traffic line markings, essential for organizing the car park and ensuring safe use. These markings can also serve as

an additional top coat for extra tire mark protection, providing a durable and visually appealing finish.

ALCHIMICA'S SOLUTIONS FOR INDOOR CAR PARK WATERPROOFING

Alchimica offers tailored solutions to meet the specific needs of indoor car park waterproofing and flooring. Our products ensure long-lasting protection against heavy traffic and chemical exposure, with ease of application and exceptional performance.

1. **Primers:** Alchimica offers a wide range of primers that can be selected based on the substrate type and porosity. Proper selection of the primer is crucial for ensuring the adhesion and effectiveness of the waterproofing system. Our primers provide a strong foundation for subsequent layers, enhancing the durability of the entire system.
2. **Waterproofing Coats:** Alchimica provides several high-performance main coats:
 - **HYPERDESMO®-ZERO:** A 100% solids, solvent-free polyurethane membrane offering high-performance characteristics, providing excellent protection in indoor environments.
 - **HYPERFLOOR-2K:** Another high-performance option that offers benefits in terms of elasticity, durability, and chemical resistance.
 - **HYPERDESMO®-D-2K:** A two-component, solvent-free polyurethane fluid that produces a strong hydrophobic membrane with moderate elasticity and outstanding abrasion and chemical resistance.
3. **Top Coats with Sand:** For the top coat with sand, Alchimica recommends using HYPERDESMO®-D-2K as a main coat but also as a top coat to the HYPERDESMO®-ZERO and HYPERFLOOR-2K products with sand broadcast into them. This step enhances durability and creates an anti-slip surface.
4. **Top Coats for Sand Encapsulation:** After the sand has been applied, an additional top coat of HYPERDESMO®-D-2K is necessary to encapsulate the

sand, locking it in place. These top coats offer exceptional abrasion and scratch resistance, suitable for heavy-duty, high-traffic areas.

5. **Traffic Line Marking:** AQUASMART-TC FLOOR PROTECT is ideal for traffic line marking and can also serve as an additional top coat for extra tire mark protection. This product enhances the visual appeal and functionality of the car park, ensuring safe and organized usage.

Indoor car parks require robust waterproofing and flooring systems to withstand vehicular traffic, potential chemical spills, and mechanical stresses. While general liquid-applied systems follow a standard structure, each company, including Alchimica, tailors its solutions based on regulations, products, and specific project needs. Alchimica's comprehensive solutions ensure long-term protection, ease of application, and exceptional performance, making them the ideal choice for modern indoor car park waterproofing projects.

EN 13813

EN 13813 is a European standard that specifies the requirements for screed materials used in constructing floor screeds, ensuring high-quality and durable flooring solutions. This standard applies to a variety of screed materials including cementitious, calcium sulfate, magnesite, mastic asphalt, and synthetic resin screeds, each tailored to meet specific properties and performance criteria for different applications and environments.

These materials are primarily intended for internal applications, although cementitious screeds can also be used externally. Each type is defined with particular properties to suit different construction needs and environments. The standard details the essential properties and performance criteria for both fresh and hardened screed materials. These include working time, consistency, pH value, compressive strength, flexural strength, wear resistance, surface hardness, shrinkage, swelling, modulus of elasticity, and bond strength. These properties are crucial to ensure that the screeds can withstand the demands of their intended applications and provide long-lasting performance. Surface preparation is another critical aspect covered by EN 13813. Proper preparation of the substrate is vital for achieving strong adhesion

between the screed and the underlying surface. This involves cleaning the substrate, removing any contaminants, and possibly applying primers or bonding agents to enhance adhesion. This step is essential to maximize the performance and durability of the screed material. The standard also provides detailed guidelines for the application of screed materials. These guidelines include mixing, placing, and curing procedures to ensure that the screed is applied correctly. Following these procedures is essential for achieving the desired performance and longevity of the flooring. Quality control measures are integral to EN 13813, ensuring that screed materials consistently meet the specified requirements throughout the manufacturing and application process. Regular testing of properties such as compressive and flexural strength, wear resistance, and bond strength is necessary to verify compliance with the standard and to ensure the reliability of the screed materials.

By adhering to EN 13813, construction professionals can ensure the quality, safety, and longevity of floor screeds, contributing to the overall durability and functionality of buildings. This standard supports sustainable construction practices by promoting the use of high-quality, reliable screed materials, thus enhancing the sustainability and preservation of building infrastructure.

PREPARATION

For successful and safe waterproofing applications specific tools and equipment are required. Each application might have different requirements.

Minimum application equipment includes protective clothing, a 1KW slow-speed drill, and a brush, roller, or airless spray machine for mixing and application. Before installing the system, the weather working conditions should be considered in order to ensure the correct and safe application of the system.



Overall, avoid extreme cold or hot surface conditions. In case of high heat, contractors may apply the products either in the morning or afternoon. The application temperature range is 5°C to 35°C, with no dew point conditions, a maximum 95% relative humidity, and substrate temperature above 3°C. Store materials cool, tools dry, and avoid application during hot hours.

Substrate: To ensure successful application, substrate preparation is crucial. New concrete should be at least 28 days old, clean, dry, and free of substances that could reduce adhesion. Dust removal is recommended, and Alchimica's primer application can be done over damp concrete.

In case of doubtful conditions, please contact ALCHIMICA's technical assistance for instructions.

REPAIR AND LEVELING MORTARS

REPAIRING

In case any spots on the concrete surface require repairs, filling, and/or smoothing such as large cracks, cavities, or surface levelling, ALCHIMICA's HYGROSMART® range of cementitious mortars may be used:

1. HYGROSMART®-FIX&FINISH (Single component, rapid-setting shrinkage-compensated, thixotropic, fiber-reinforced, cementitious mortar applied in a single layer

from 3 to 40 mm thick, for repairing and smoothing concrete, certified according to EN1504-03, Type R4 CLASS III), or

2. HYGROSMART®-BUILDING-45-THIXO (Single-component, shrinkage-compensated, thixotropic, fiber-reinforced cementitious repair mortar, certified according to EN1504-03, Type R4 CLASS III), or

3. HYGROSMART®-BUILDING-F (Single-component, reinforced, quick-setting, cementitious repair mortar with excellent adhesion and mechanical properties, easy application in horizontal/vertical substrates. Long pot life allows the application of thick coats without cracking. CE Certified as Class R3 class III repair mortar according to EN 1504-03.

4. HYGROSMART®-MAK-FLOW (Single-component, highly flowable and shrinkage compensated mortar for structural repairs and anchoring, certified according to EN 1504-6: 2006 (Anchoring cementitious mortar for strengthening concrete by installing reinforcing steel) and EN 1504-3: 2005, Class R4(Hydraulic



mortar (R4-CC) for structural repair of concrete in building and civil engineering works).

LEVELING

In cases where the concrete needs to be levelled or slopes need to be created prior to the installation of the waterproofing membrane, the following products from the HYGROSMART® range can be used, depending on the requirements and desired outcome.

1. **HYGROSMART®-MAK FLOW** (as described above)
2. **HYGROSMART® -DUR CEM 3K** (Three-component, epoxy modified mortar, waterborne, solvent-free, low viscosity, self-levelling, quick curing, zero VOC. Primer for flooring and waterproofing applications, floor-levelling compound. Will effectively seal the substrate as a solution to the problems arising in waterproofing applications on porous and/or humid concrete. The material is available as SELF LEVELLING (**HYGROSMART®-DUR CEM 3K SL**) or THIXOTROPIC (**HYGROSMART®-DUR CEM 3K THIXO**).

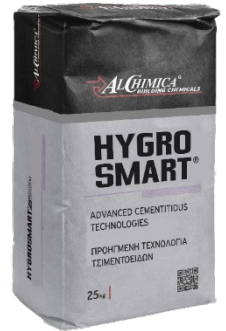

PRIMER SELECTION

After checking the weather conditions and having completed the substrate preparation along with any repairs that might be needed, you can start the waterproofing system's build-up with the selection of a suitable primer. ALCHIMICA's primer range provides unique properties for different substrates.

SUBSTRATE AND CONDITIONS	CONCRETE	HUMID CONCRETE	GYPHUM	METAL STEEL	POROUS CERAMIC TILES	GLASS / GLAZY TILES	PVC MEMBRANES	TPO MEMBRANES	BITUMEN MEMBRANES	LOW TEMPERATURE APPLICATION	VAPOR BARRIER	NEGATIVE PRESSURE / RISING HUMIDITY (tank)
PU PRIMERS												
PRIMER-PU	X	-	-	X	-	-	-	-	-	-	-	-
MICROPRIMER-PU	X	-	-	X	X	-	-	-	-	-	-	-
MICROSEALER-PU	X	X	X	X	X	-	-	-	-	-	-	-
MICROSEALER-50	X	X	X	X	X	-	-	-	-	-	-	-
GEODESMO 50	X	X	-	X	-	-	-	-	-	X	-	-
UNIVERSAL PRIMER-2K 4060	X	X	-	-	-	-	-	-	X	X	-	-
PRIMER T	-	-	-	-	-	X	-	-	-	-	-	-
PRIMER W	-	-	-	-	-	X	-	-	-	-	-	-
PRIMER TPO/FPO	-	-	-	-	-	-	-	X	-	-	-	-
PRIMER PVC	-	-	-	-	-	-	X	-	-	-	-	-
WATER-BASED PRIMERS												
AQUADUR	X	X	X	-	-	-	-	-	-	-	X	X
AQUASMART-DUR	X	X	X	-	-	-	-	-	-	-	X	X
AQUASMART-PRIMER PU-2K	X	X	-	-	-	-	-	-	-	X	-	-

ALCHIMICA's primers are designed to secure your waterproofing application in every substrate by strengthening the substrate, stabilizing, and sealing it, offering remarkable adhesion with their respective main membranes and sealants.

SEALING SOLUTIONS



HYPERSEAL®-EXPERT-150 is a low-modulus expansion and construction joints PU sealant designed to ensure a bubble-free cure even in high temperature and humidity conditions. It exhibits excellent thixotropy, making it suitable for large expansion joints. The ratio width to depth should be 2:1 subject to a minimum depth of 10mm. It cures by reacting with atmospheric humidity, producing a joint sealant with a 50% joint movement accommodation factor, elongation >700% (ASTM D412 / EN-ISO-527-3), and excellent adhesion to a variety of substrates (Adhesion to concrete >20 kg/cm² (>2 N/mm² ASTM D4541) with or without the use of special primers. The sealant's extrusion rate and tooling remain consistent across various temperature and humidity conditions. HYPERSEAL®-EXPERT-150 is CE certified according to EN 15651-1:2012 (Sealants for Facades) and 15651-4:2012 (Sealants for Floor Joints with Foot traffic). HYPERSEAL®-EXPERT-150 is a highly flexible PU sealant, with elastic recovery of >70% (EN ISO 7389) allowing for the movement and expansion of structure components, preventing cracks, and ensuring a lasting seal. It adheres to various substrates, making it durable and able to withstand harsh environmental conditions and heavy traffic loads. As a PU sealant, it is also chemically resistant, protecting the structure from corrosion. Because of its excellent chemical and hydrolysis resistance, it is widely used for sealing joints in swimming pools and chemically treated water environments. HYPERSEAL®-EXPERT-150 provides excellent waterproofing, preventing moisture ingress, and has high elasticity, allowing for flexibility and elasticity. It does not shrink as it cures, ensuring no gaps or openings in the sealed

joint. Its excellent heat resistance makes it suitable for application where exposure to temperatures $>60^{\circ}\text{C}$ takes place and its resistance to cold allows the sealant to remain elastic even down to -40°C (service temperature range -40 to $+80^{\circ}\text{C}$). It has tack free time (@ 77°F (25°C) & 55% RH) of 2.5-3.5 hours and a cure rate of 2-3 mm/day, low VOC content, and remains resistant and unaffected by microorganisms, fungi, and algae

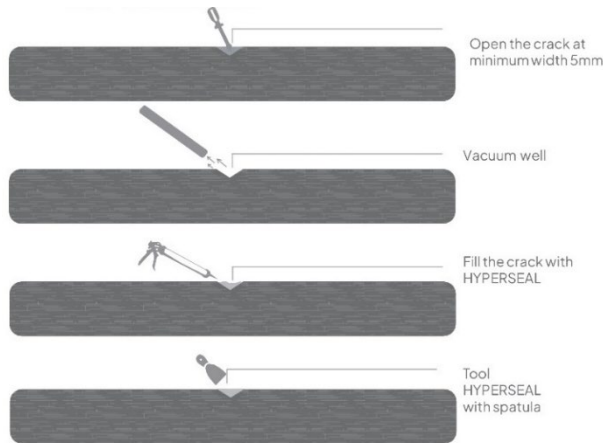

growth, making it the most versatile PU sealant, usable in a variety of applications.

HYPERSEAL®-EXPERT-150 is available in various colors and compatible with a wide range of construction materials in general. Can be easily applied using standard

caulking or gun techniques.

REINFORCEMENT OF WATERPROOFING MEMBRANES WITH GEOTEXTILE

Geotextile reinforcement is a crucial component in the construction industry, providing long-term protective solutions for waterproofing systems. These fabric-made sheets are used in various applications, including drainage and construction projects. They are divided into two categories: non-woven and woven geotextiles. Woven geotextiles have high load capacity and tensile strength, making them ideal for stabilization and reinforcement applications. Non-woven geotextiles, on the other hand, offer durability and ease of application benefits. Nonwoven geotextiles are manufactured by binding short and long fibers together through needle punching or other alternative methods. The term “pressed” in relation to non-woven geotextiles usually refers to the process of needle punching. In this context, “pressed” refers to a non-woven geotextile that has undergone the needle punching process, while “unpressed” usually refers to a non-woven geotextile before this process. The needle-punching process can improve the strength of the geotextile. For cold climatic conditions, it is recommended to choose the PRESSED geotextile.

UNHSOUND SURFACES AND DETAILS



WOOD



BITUMEN MEMBRANES



SCREED



METAL SEAMS

Geotextiles protect and separate membranes from structures due to their higher pre-break elongation capacity than other materials like glass mesh or fiberglass mesh. They can follow the movement of elastomeric waterproofing

materials, achieving reinforcement and long-term durability. However, unsound substrates often have high movement or large cracks, which can cause problems on unarmed waterproofing membranes. Geotextiles can prevent future cracks by sealing and protecting details in areas like roofs, flashing, and joints, and repairing existing cracks and gaps. They are often made of Polyester, which is a strong fiber with excellent oxidation resistance and good mechanical stability. It offers strong oxidation or mildew resistance because it stays resilient when wet. It is used as a reinforcement material embedded between the waterproofing coats, so it does not have direct exposure to the conditions. In this case, any resistance concerns those materials that are in direct contact with the environment and conditions. The HYPERDESMO® System remains elastic at -40°C . Another very important advantage of our materials that are in the technology of liquid polyurethane waterproofing membranes is the fact that they can easily be reinforced with geotextile if needed.

ALCHIMICA offers a high-tensile strength range of non-woven geotextiles made of 100% polyester fibers, manufactured with the needle punching process. They can be applied on the full surface between the first two layers of the HYPERDESMO®-ADY-610/810, providing the required reinforcement for certain applications, such as over old bitumen membranes and unsound screeds.

They are suitable for solvent-based or water-based liquid waterproofing systems.

GEOTEXTILE-50 (1X200m)

GEOTEXTILE-50 is a non-woven geotextile, from 100% polyester fibers, manufactured with the needle punching process.

COLOR	PACKAGING
WHITE	200m



GEOTEXTILE-50 PRESSED (1.02X100m) (0.17X100m)

GEOTEXTILE-50 PRESSED is a non-woven geotextile, from 100% polyester fibers, manufactured with spun-lacing process (hydro-entanglement).

COLOR	PACKAGING
WHITE	100m
WHITE	100m



GEOTEXTILE-45 PRESSED (1.02X100m)

COLOR	PACKAGING
WHITE	100m ²



METHOD STATEMENT

INDOOR CAR PARK SOLUTION BASED ON THE HYPERFLOOR®-2K.

GENERAL SYSTEM CONDITIONS

EQUIPMENT

For successful and safe applications specific tools and equipment are required. Each application might have different requirements in terms of application and protection equipment.

The following application equipment is at minimum required:

- Protective clothing: Protective overalls, masks, and gloves.
- Mixing equipment: 1KW slow speed drill, 400 or 500 rpm, and suitably sized mixing vessel.
- When stirring (or pigmenting) take care not to introduce air into the fluid, which may result in bubbling on the cured membrane. Stirring can either be done manually or with a low speed (300 rpm) mixer.
- Application equipment: Brush, roller, notched trowel, squeegee, rubber spatula, caulking gun, spatula. Specific airless spray machines can also be used. Caulking guns.
- Extra equipment: Digital scale or other measuring equipment

Products can be applied with a variety of equipment. Please choose the desired equipment and method of application according to your preferences and experience after consulting the proposed method of application on TDS of the Product.

APPLICATION WITH AIRLESS SPRAY MACHINE.

For the application of ALCHIMICA's liquid applied PU systems we recommend the following minimum performance for the equipment to be used. This however it is not exclusive, as applicators should use our products with the equipment that is more suitable according to their application method, prior experience, and expertise:

- Minimum pressure: around 200-250 bar
- Minimum capacity: 5.1 lt/minute
- Minimum nozzle diameter: 0.83mm (0.033 inches)
- Examples of such minimum-spec equipment:
 - ✓ *Wagner Heavycoat HC 940 E-SSP Spraypack*
 - ✓ *Graco Mark-X*
 - ✓ *Larius Thor*

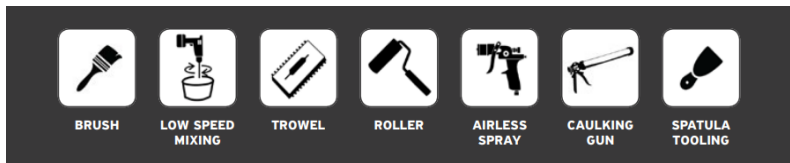

- Application temperature range: 5°C to 35°C.
- Avoid dew point conditions during application.
- Relative humidity must be a maximum of 95% and substrate temperature must be at least 3°C above measured dew point temperatures.
- Do not apply under rain or snow.
- If temperature is above 35°C, the following guidelines are recommended:
 - Store materials in a cool environment, avoiding exposure to direct sunlight.
 - Keep application tools cool and dry.
 - Try to avoid application during the hottest hours of the day.

SURFACE PREPARATION

THE FOLLOWING FACTORS PRIOR TO APPLICATION SHOULD BE CHECKED:

- ✓ Substrate type and condition.
- ✓ Previous substrate mechanical preparations (sanding, polishing, shot blasting, or milling)
- ✓ Porosity of the surface
- ✓ Existing cracks or damaged areas.
- ✓ In existing dilatation joints, remove old material, clean it, and replace it with HYPERSEAL®.
- ✓ Existing membranes or coatings.
- ✓ The substrates must be both durable and cohesive. Check the substrate for contamination (oil, grease, etc.).

CONCRETE SUBSTRATES

Concrete substrates are used in the construction of roofs and foundations in modern architectural designs. However, because concrete is a porous surface exposed to different climatic conditions, it can absorb water which can then cause damage. Waterproofing is a basic need at almost all stages of construction work, in order to protect structures from the adverse effects of moisture and water ingress. In the case

of exposed concrete roofs, it is vital to avoid any water leak in order to prevent any wear and corrosion of reinforcing steel in the concrete structure.

ALCHIMICA's high-quality concrete roof waterproofing and protection systems consist of quality products that hold excellent workability, durability, elasticity, and resistance to weather, chemical, mechanical, and thermal effects, as well as to UV radiation on either flat or sloping roofs.

Standard concrete substrate conditions

- Hardness: R28 = 15 MPa.
- Humidity: W < 10%.
- Temperature: 5-35 °C.
- Relative humidity: < 85%

PREPARATION

Proper preparation of the concrete substrate is essential for complete adhesion and successful application.

- New concrete or other cementitious substrates should be at least 28 days old.
- The substrate should be clean and free of loose particles, oil, and grease.
- The substrate should be free of any irregularities. If needed, it should be ground with the appropriate mechanical equipment in order to achieve a flat and sound surface.
- The substrate should be free of dust. Vacuum treatment or/ and high-pressure washing is recommended to remove dust.
- Primer application can be done over damp concrete too. But any ponding water should be removed before primer application.
- Metal details should be free of rust, oils, and old paints.
- The surface of PVC pipes should be treated with sandpaper in order to become rough.
- Surface irregularities can be filled with the appropriate HYGROSMART® products.
- For concrete levelling or sloping the appropriate HYGROSMART® products must be used.
- For more information about surface preparation please contact our technical assistance team.

MANDATORY DISCLAIMER BEFORE APPLICATION:

Testing the products to be used in this build-up application on the specific substrate and conducting mock-up tests are essential steps to ensure good adhesion. Mock-up tests replicate real-world conditions and provide a practical way to evaluate the performance of the products in situ. Pull-out tests conducted on these mock-ups help assess the bond strength between the products and the substrate, giving valuable insights into their adhesion capabilities.

By testing the products on the specific substrate and conducting mock-up tests, any potential issues or concerns regarding adhesion can be identified and addressed before full-scale implementation. This proactive approach helps mitigate risks associated with poor adhesion, ensuring the long-term durability and effectiveness of the build-up system.

ALCHIMICA advises the thorough testing of the system to be performed prior to proceeding with full surface application in order to determine the suitability of the system based on project requirements.

SYSTEM PRODUCTS BUILD-UP

	PRODUCT	CONSUMPTION
1. PRIMER	AQUASMART-DUR	150-200 gr/m ² Subject to porosity
	AQUASMART PU PRIMER 2K	
	UNIVERSAL PRIMER 2K 4060	
2. SEALANT	HYPERSEAL [®] -EXPERT-150	Subject to project needs
3. MAIN WATERPROOFING MEMBRANE & TRAFFIC TOP COAT	HYPERDERFLOOR-2K	Total consumption: 2.6 kg/m ²



CERTIFIED
PRODUCTS

4. TOP COAT / SAND ENCAPSULATION	HYPERDESMO-D-2K	0.4 kg/m ² per coat
5. SILICA SAND BROADCAST	recommended granulometry: 0.3-1mm	2.6 kg/m ²
6. STAIN FLOOR PROTECTION & TRAFFIC LINE MARTING (OPTIONAL)	AQUASMART-TC-2K-FLOOR-PTOTECT	Subject to project needs

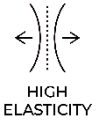
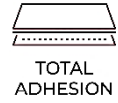

SUBSTRATE PRIMING



PRIMER	AQUASMART-DUR / AQUADUR	AQUASMART-PU PRIMER 2K	UNIVERSAL PRIMER-2K-4060
CONSUMPTION	- 150-200 gr/m ² - water/humidity barrier –three coats with total cons. of 500-600 gr/m ²	- 150-200 gr/m ² per coat	- 150-200 gr/m ² per coat - subject to substrate porosity
COMPOSITION	WATER BASED EPOXY	WATER BASED PU	100% SOLIDS PU
APPLICATIONS METHODS	brush, roller	brush, roller	brush, roller
TACK FREE TIME, @ 77 °F (25°C) & 55% RH	3-5 Hours	1-2 Hours	1-2 Hours
RECOAT TIME OF PRODUCT WHEN NEEDED	When the material has hardened to the degree where it can no longer be punctured by fingernail 6-24 Hours	1-2 Hours	1-2 Hours
NEXT COAT TIME (HYPERDESMO® ZERO MEMBRANE)	Once the colour on the current coat goes from milky white to transparent 6-24 Hours	2-24 Hours	3-6 Hours
RECOMMENDED DILUTION	10% WATER	10% WATER	5-10% SOLVENT-O1
ADDITIVES	X	X	X
COLORS	TRANSPARENT	TRANSPARENT	TRANSPARENT
POT LIFE	1 Hour	25 min	20-30min
COMPONENTS	TWO COMPONENTS	TWO COMPONENTS	TWO COMPONENTS

Choose a suitable primer for your project needs and requirements:

■ AQUASMART-DUR is a medium viscosity epoxy-based primer. It is a water-based epoxy primer and humidity barrier, suitable for application in closed spaces too. It is a two-component product with a 1:1 mixing ratio by volume with zero VOC, low odor, and non-flammability. It has a long pot life while being fast curing, easy to clean, and suitable for concrete and humid concrete too.

Mixing: Mix the two components well manually or using a low speed (300 rpm) mixer.

Application: You choose to apply this primer over a sound concrete surface. AQUASMART-DUR primer will create a slight film sealing the concrete and increasing the adhesion. After the AQUASMART-DUR application, you should wait at least 12 hours to apply the main membrane. The main membrane application has to be done within 48 hours after the AQUASMART-DUR application. AQUASMART-DUR is completely solvent-free and low VOC primer. If a negative pressure humidity barrier is required, increase total consumption of AQUASMART-DUR at a minimum of 500 gr/m² in 3 successive layers (150-200gr/m² per coat)

■ AQUASMART®-PU PRIMER 2K is a revolutionary polyurethane water-based primer. It is a 100% polyurethane product that can be applied on damp concrete, making it an ideal same-day primer. The product is solvent-free and zero VOC, making it suitable for both indoor and outdoor use. This two-component, 1:1 volume product is fast curing, low-odor, safe, non-flammable, and non-IMO, suitable for closed spaces. It has a long pot life, easy clean-up, and strong adhesion, even on damp or green concrete. It can be used on concrete, humid concrete, metal/steel, aluminum, glass, and wood and can be applied with brush, roller, or airless spraying. The product is recommended for use as a primer for HYPERDESMO® and AQUASMART® based products and for difficult main coat applications like POLYUREA-based materials.

Mixing: Mix the two components well manually or using a low speed (300 rpm) mixer.

Application: You choose this primer when the application temperature is below 15°C and when you need a fast-curing primer that will allow same day application. Apply with roller in one or two thin coats with total consumption of 150 gr/m². Following application of AQUASMART-PU PRIMER 2K, the main membrane may be applied within 2-24 hours.

■ UNIVERSAL PRIMER-2K-4060 is a fast-curing polyurethane primer that allows same-day application for both primer and main coat membrane. It is ideal for cold weather or low humidity conditions, as its curing time is not significantly affected by climate making it suitable for use in cold climates or low humidity conditions. The 100% polyurethane product can be applied on damp concrete and performs excellent adhesion to various surfaces (exceeding the requirements of EOTA). It is non-toxic and has zero VOC. The product is an excellent bitumen-oil barrier and is solvent-less, making it suitable for closed spaces.

Mixing: Mix the two components well manually or using a low speed (300 rpm) mixer. Mix the two components well. In high temperatures, pour mixture in shallow, wide container in order to increase pot life.

Application: You choose this primer when you need an effective oil barrier and a fast curing, solventless PU primer. UNIVERSAL PRIMER-2K-4060 is an ideal solution when working over old concrete surfaces contaminated by oils, grease etc., because it creates a very effective “oil barrier” film that protects the new coating. UNIVERSAL PRIMER-2K-4060 is solvent free and zero VOC primer and suitable for both indoors

and outdoors applications. Apply with brush or roller in thin coat with total consumption not exceeding 200 gr/m². In order to achieve such a small consumption, you can dilute UNIVERSAL PRIMER-2K-4060 with 5-10% of SOLVENT-01 (After thinning the product no longer has zero VOC). Main coat must be applied maximum 6 hours after primer application.

Tip: For increased pot life and/or reduced consumption, add 5-10%. Empty mixed pail contents either in a shallow container or directly on the surface to be primed in order to increase the pot life further.



Notes:

1. If it rains after the primer and before the main coat application, you may need to apply one coat of primer again.
2. More primers are available for special cases, surfaces, and weather conditions.
3. For more information about surface preparation please contact our technical assistance team.

DILATATION JOINTS, INNER ANGLES & SMALL CRACKS

Concrete expansion joints are small gaps in structures designed to prevent cracks, absorb stresses, and allow soil movement. They allow independent movement and thermal expansion without inducing stress. Concrete is susceptible to cracks due to its non-elastic nature, so joints are strategically placed to prevent failure. However, structures with expansion joints are susceptible to water leaks, so waterproofing and applying a durable sealant are essential to maintain flexibility and allow the joint to function properly. All dilatation joints, inner angles, wall-floor connections, cracks,

drainage details, pipes, and other elements of equipment mechanically installed on the structure (air conditioning, antennas, photovoltaic systems, etc.) must be treated.

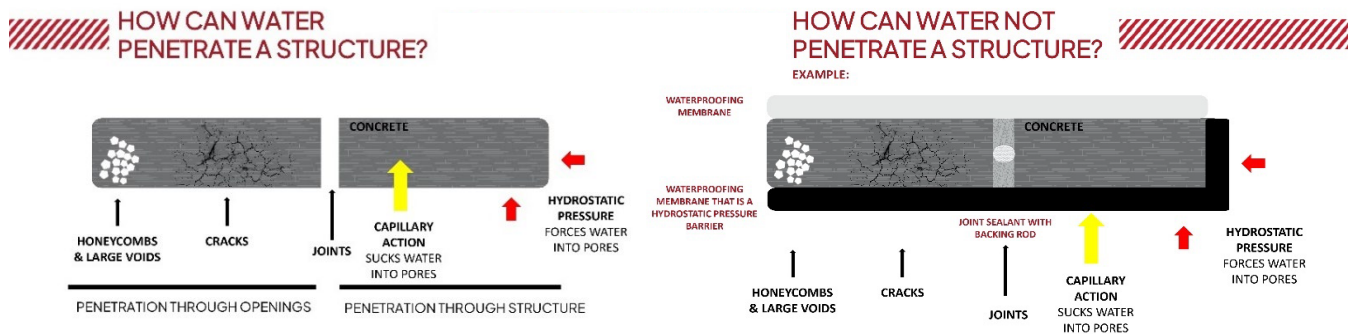

Dilatation joints and inner angles should be treated with HYPERSEAL®-EXPERT-150 or HYPERSEAL®-25LM-S, polyurethane based sealants.

Clean joints thoroughly, and ensure that no dust, oil, grease, wax contaminants, or silicone remains are present. For many applications, primer is not obligatory. However, in case of application on porous or/and wet substrate the primer is required, as there is a possibility of air bubbles blown into the uncured sealant if the substrate temperature rises.



After the primer is cured, apply in dilatation joints the right backing material (where needed) – an open cell polyurethane or a closed cell polyethylene backing rod. Be sure that when applying a closed cell polyethylene backing rod, its outer skin is not punctured, as rising temperature may cause bubbles. Backing rod application is important as it ensures the correct width-to-depth ratio and provides a firm backing against which the sealant can be tooled off. Apply the sealant HYPERSEAL®-EXPERT-150 or HYPERSEAL® 25 LM-S.



■ HYPERSEAL®-EXPERT-150 is a low modulus sealant, formulated to ensure bubble free cure even at very high temperatures and humidity climatic conditions. The product displays excellent thixotropy allowing its use even in very large expansion joints. It cures by reaction with atmospheric humidity to produce a joint sealant with a 50% joint movement accommodation factor and excellent adhesion on many types of substrates (concrete, fibrous cement, mosaic, cement roof tiles, wood, also glass, aluminum, steel, polycarbonate, etc.). The extrusion rate and tooling of the sealant remain the same throughout a very wide range of temperature and humidity conditions.

■ HYPERSEAL® 25LM-S is a low modulus expansion joint sealant. It has been modified in order to give enhanced thixotropic properties. It cures by reaction with atmospheric humidity to produce a joint sealant with a 50% joint movement accommodation factor and excellent adhesion on substrates traditionally problematic for PU sealants, e.g. glass, aluminum, steel, polycarbonate, etc. Additionally, the sealant has been modified in order to have an extrusion profile identical to hybrid PU or MS technology. The extrusion rate and tooling of the sealant remain the same throughout a very wide range of temperature and humidity conditions. The sealant is easy to apply even in very low temperatures.

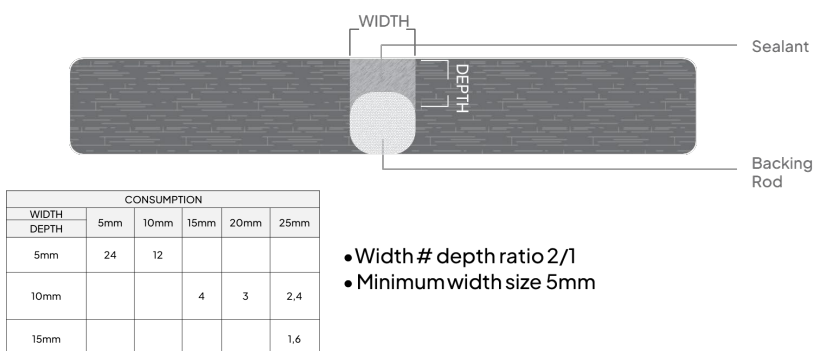

Slide the sealant HYPERSEAL®-EXPERT-150 or HYPERSEAL® 25 LM-S into the sealant dispensing gun, cut off the very end of the sealant

packaging, and fit the gun with the nozzle. The nozzle should be cut to deliver the right

bead size. Extrude the sealant into the joint ensuring that no air is trapped in the joint. Tooling is recommended immediately after the application of sealant. The ratio width to depth should be 2:1 subject to a maximum depth of 25mm.

NOTE:

- Tool the sealant with a spatula.
- Do not use any solvent, alcohol, or soap to smooth the material.

POLYETHYLENE BACKER ROD

Special backer rod made of extruded polyethylene for joints where HYPERSEAL® sealants will be used.



SIZE	PACKAGING
F6	1500m
F10	680m
F15	250m
F20	180m
F25	100m
F30	100m
F40	100TEM
F50	65TEM

TREATMENT OF DETAILS

All connections, cracks, drainage details, pipes, and other elements of equipment mechanically installed on the structure (air conditioning, antennas, photovoltaic systems, etc.) should be treated. Select the preferable treatment using sealants HYPERSEAL®-EXPERT-150, HYPERSEAL® 25LM-S, , or/and HYPERDESMO®-PARTICULAR.

Clean details and cracks thoroughly, and ensure that no dust, oil, grease, wax contaminants, or silicone remains are present. For many applications, primer is not obligatory. However, in case of application on porous or/and wet substrate, the primer is required, as there is a possibility of air bubbles blown into the uncured sealant if the substrate temperature rises. Select a suitable primer according to the substrate type and needs.

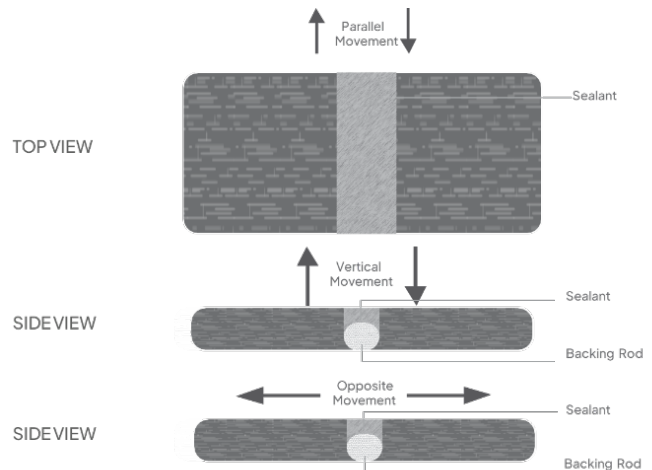

Dilatation joints, inner angles, and small cracks should be treated with HYPERSEAL®-EXPERT- 150 polyurethane-based sealant or any other suitable HYPERSEAL® sealant as described above.

FIBER-REINFORCED PU: HYPERDESMO®-PARTICULAR.



This is an alternative option when application of HYPERDESMO® System with GEOTEXTILE is difficult. HYPERDESMO®-PARTICULAR is a thixotropic and fiber-reinforced, one component polyurethane liquid membrane used for waterproofing and protection of roof detail structures. Due to its unique formulation, it cures rapidly to form a bubble free thick layer membrane with excellent mechanical properties. HYPERDESMO®-PARTICULAR is an effective sealing material for the treatment of installation details on roofs, such as chimneys, pipes, photovoltaic systems, air-conditioning units, and gutters. This product is ideal for usage during the winter months or in climates with relatively low humidity.

Apply the material with a spatula or a brush with the consumption required to fill in the gaps, but with a thickness of no more than 2 mm. It can be applied as the only sealing material as well as together with HYPERSEAL®-EXPERT-150 or HYPERSEAL® 25 LM-S. In this case, the depth is filled in with sealant HYPERSEAL®-EXPERT-150, and then the irregularities on the top part are treated with thixotropic HYPERDESMO®-PARTICULAR.

NOTE:

- Clean tools and equipment first with a paper towel and then using SOLVENT-01.

MAIN WATERPROOFING MEMBRANE

HYPERFLOOR-2K is a 100% solid, polyurethane self-leveling flooring resin. This advanced flooring

solution is a two-component, solvent-free polyurethane material that, upon curing, produces a strong, flexible film with excellent adhesion to various surfaces. The product is based on pure hydrophobic polyurethane resin combined with special inorganic fillers, providing the material with outstanding abrasion and chemical resistance. HYPERFLOOR-2K boasts excellent mechanical properties,

including high tensile and tear strength, as well as temperature resistance ranging from -40°C to 90°C, and it can withstand short-term temperature spikes up to 200°C. This broad temperature tolerance ensures that the material remains durable and crack-free, even under extreme conditions. With HYPERFLOOR-2K, achieving any desired thickness from 1mm to 10mm in just one single coat is possible, making it an incredibly versatile flooring option. The material's flexibility across a wide temperature range ensures a seamless, crack-free floor surface. Its primary applications include both light traffic industrial areas and high traffic areas when used with a traffic-resistant topcoat. Typical examples of its application are in car parks, hospitals, food industries, chemical industries, and industries that treat liquid materials. HYPERFLOOR-2K's unique properties also make it an ideal solution for waterproofing Secondary Containment Tanks. For effective waterproofing, HYPERFLOOR-2K should be applied at a minimum thickness of 2mm, with a minimum total consumption of 2.6 kg/m².

Mixing: Use a low speed (300rpm) electric drill.

Application: Apply undiluted with a notched trowel, squeegee or roller. As soon as the material is applied, use a spiked roller to remove entrapped air. With this material you can achieve any desired thickness (from 1mm up to 10mm) in just one single coat. It is a flexible material within a wide temperature range, so you can achieve a seamless, crack-free floor surface.

HYPERFLOOR-2K	
CONSUMPTION	Minimum: 2,6 kg/m ²
APPLICATIONS METHODS	brush, roller, airless spraying
TACK FREE TIME, @ 77 °F (25°C) & 55% RH	4-6 Hours
APPLICATION OVER PREVIOUS COAT (PRIMER)	Depending on the primer curing time
RECOAT TIME OF PRODUCT	6-24 Hours
NEXT COAT TIME (TOPCOAT)	6-24 Hours
ADDITIVES	<ul style="list-style-type: none"> • THIXO-TOOL • ACCELERATOR-300A
	CHECK THE TDS FOR COMPATIBILITY
COLORS	GREY, NEUTRAL
COMPONENTS	SINGLE COMPONENT

Thickness: The dry film thickness is calculated based on the application and can be determined by considering that 1.3kg/m² of HYPERFLOOR-2K will give you 1mm thickness. Recommended consumption for car park applications is 2.0-2.5 kg/m².

Potlife: 20-30 minutes @ 25 oC & 55% RH. Tip: HYPERFLOOR-2K is an aromatic polyurethane system and therefore will discolor when exposed to UV. For color protection, traffic/abrasion resistance as well as providing an easy cleaning the use of an additional pigmented Top Coat is recommended.

TYPES OF APPLICATIONS

APPLICATION

With HYPERFLOOR-2K you can achieve any desired thickness (from 1mm up to 10mm) in just one single coat. The dry film thickness is calculated based on the application and can be determined by considering that 1.3kg/m² of HYPERFLOOR-2K will give you 1mm thickness.

PIGMENTATION OF HYPERFLOOR-2K NEUTRAL

HYPERFLOOR-2K it is either pre-pigmented from the factory in grey colour or it comes in NEUTRAL version that must be pigmented with ALCHIMICA's PIGMENT PASTES only (10% max).

At a maximum ratio of 10% by weight, the PIGMENTS PASTES are designed to be compatible with ALCHIMICA's products, offering high hiding power to the neutral version of HYPERFLOOR-2K. Pour the PIGMENT PASTE content of the pail into the product at a maximum ratio of 10% by weight. Mix thoroughly using a low-speed electric mixer until the product homogenizes. Apply the product as per standard application instructions.

TRAFFIC TOP COAT

In areas where chemical resistance is critical, applying a topcoat is essential. In such cases, HYPERDESMO-D-2K is highly recommended due to its exceptional chemical resistance properties. HYPERDESMO-D-2K is a two-component, solvent-free polyurethane coating known for its superior resistance to aggressive chemicals. Formulated with pure hydrophobic polyurethane resins and special inorganic fillers, it resists a wide range of chemicals, including acids, bases, solvents, and salts. This robust chemical resistance ensures that HYPERDESMO-D-2K remains effective in harsh industrial environments, maintaining its protective qualities over time.

HYPERDESMO®-D-2K	
CONSUMPTION	0.2 -0.4kg/m ² per coat In Total: 0.8 kg/m ² depending on project requirements
APPLICATIONS METHODS	brush, roller
TACK FREE TIME, @ 77 °F (25°C) & 55% RH	1-2 Hours
RECOAT TIME OF THE PRODUCT	4-24 Hours
POT LIFE	20 MIN @25°C
COLORS	GREY, NEUTRAL
COMPONENTS	TWO COMPONENTS

The cured membrane of HYPERDESMO-D-2K exhibits excellent resistance to various chemicals, remaining unaffected by acetic acid (10%), chloride (10%), citric acid (10%), and nitric acid (10%). It also withstands exposure to fatty acids, gasoline, hydrogen peroxide (10%), lactic acid (25%), potassium hydroxide (10%), sodium hydroxide (10%), sodium hypochlorite (3%), and sulfuric acid (10%). However, it does degrade when exposed to acetone, cresol, methylene chloride, and formic acid (10%) over extended periods. For detailed information please refer to products TDS.

HYPERDESMO-D-2K's chemical resistance makes it an excellent topcoat for projects requiring high chemical resistance. It enhances the durability and longevity of underlying layers, providing a robust barrier against chemical attacks. This makes it

suitable for protecting industrial floors, car parks, chemical storage tanks, effluent treatment tanks, and sewage tanks from chemical exposure and mechanical wear. For car park topcoat applications, HYPERDESMO-D-2K is applied at approximately 600-800 grams per square meter in 2-3 coats using a roller or rubber squeegee, with a thickness of about 0.3 kg/m² per coat. The recoating interval is between 2 to 4 hours, not exceeding 24 hours, ensuring efficient project completion within a single day.

In environments where aesthetic appearance is important, especially those exposed to sunlight, it is recommended to use a pigmented topcoat over HYPERDESMO-D-2K to prevent discoloration. These topcoats preserve the color while maintaining the chemical resistance and protective properties of HYPERDESMO-D-2K. HYPERDESMO-D-2K's combination of chemical resistance, mechanical strength, and ease of application makes it a highly effective solution for protecting surfaces in chemically aggressive environments, ensuring long-term performance and reliability in industrial applications.

Mixing: Pour component A into component B container and use a low speed (300 rpm) mixer.

Application: Apply coats with roller or rubber squeegee. Do not leave more than 24 hours between coats

Sand broadcasting: For traffic you should finally apply HYPERDESMO-D-2K combined with silica sand. The application is done using a roller or rubber squeegee to apply 2 coats at approximately 0.8 kg/m² with each coat being about 0.4 kg/m². The recoating interval is between 2 to 4 hours, not exceeding 24 hours, ensuring efficient project completion within a single day. If anti-slippery effect is required, natural dry quartz sand can be broadcasted over the fresh 1st coat of HYPERDESMO-D-2K, before the 2nd coat of HYPERDESMO-D-2K. Any excess sand should be vacuum removed from the 1st coat.

Pot life: 20 minutes @ 25 oC & 55% RH.

TYPES OF APPLICATIONS

APPLICATION BY COATS

Per coat: 0.2-0.4 kg/m².

Total consumption: 0.8 kg/m²

Apply more coats depending on project requirements and system build-up.

PIGMENTATION OF
HYPERDESMO®-D-2K NEUTRAL

HYPERDESMO®-D-2K it is either pre-pigmented from the factory in grey colour or it comes in NEUTRAL version that must be pigmented with ALCHIMICA's PIGMENT PASTES only (10% max).

At a maximum ratio of 10% by weight, the PIGMENTS PASTES are designed to be compatible with ALCHIMICA's products, offering high hiding power to the neutral version of HYPERDESMO®-D-2K. Pour the PIGMENT PASTE content of the pail into the product at a maximum ratio of 10% by weight. Mix thoroughly using a low-speed electric mixer until the product homogenizes. Apply the product as per standard application instructions.

TRAFFIC LINE MARKING

Tires can indeed leave stains on floor substrates due to the oils and chemicals they contain. These substances, including oils and plasticizers designed to keep rubber flexible, can migrate out of the tires and onto the floor over time. This leaching process can cause noticeable discoloration or staining, especially on lighter surfaces. The heat and pressure exerted by vehicles can accelerate this leaching, exacerbating the problem.

AQUASMART-TC 2k FLOOR PROTECT	
CONSUMPTION	0.150 kg/m ² per coat In Total: 0.3kg/m ² in two or more coats.
APPLICATIONS METHODS	brush, roller, airless spraying
TACK FREE TIME, @ 77 °F (25°C) & 55% RH	-
APPLICATION OVER PREVIOUS COAT	It must be applied WITHIN 24-72 hours, depending on weather conditions.
RECOAT TIME OF THE PRODUCT	When completely dry
POT LIFE	-
COLORS	TRANSPARENT
COMPONENTS	TWO COMPONENTS

To protect floor substrates from tire marks, particularly in parking lots, specific products and application procedures are recommended. One such product is AQUASMART-TC-FLOOR PROTECT, which is effective in shielding the flooring system from tire marks. Traffic lines should be applied using AQUASMART-TC 2K FLOOR PROTECT, pigmented to the desired color, within 48 hours after the final coat of HYPERDESMO-ADY-810. This coating is versatile and can be easily pigmented with various water-based color pastes.

The application process involves using a roller to apply the product at a total consumption of 0.15-0.30 kg/m² in one or two coats. Light pedestrian traffic is permissible after 24 hours, while vehicle traffic should be allowed only after 5 days from the final layer application.

AQUASMART® –TC 2K FLOOR PROTECT is a two-component, water-based, aliphatic coating renowned for its exceptional performance in a multitude of applications. It is highly recommended as a top coat for protecting epoxy and polyurethane self-leveling floors, thanks to its excellent UV, chemical, water, and abrasion resistance. This product also offers superior resistance to staining and can be easily pigmented with off-the-shelf water-based pigment pastes in a 5-10% by weight ratio, depending on the required hiding power.

This product is particularly suitable as a UV protective (pigmented) top coat for self-leveling polyurethane and epoxy floors, serving as a final protective layer for car parks, and for industrial paint applications. Its features and benefits include being water-based, easy to apply, fast curing, and having excellent UV resistance. Additionally, it can be easily pigmented with water-based pigment concentrates, has a long pot life, and provides excellent interlayer adhesion.

By using AQUASMART® –TC 2K FLOOR PROTECT as a top coat, floors can be effectively shielded from the staining effects of tire oils and chemicals, ensuring both longevity and aesthetic appeal.

Mixing: Use a low speed (300 rpm) mixer. Add the second component and continue mixing for a few minutes. Add the pigment paste 5-10% by weight and mix until product has a homogenous color.

Application: Application of AQUASMART®-TC 2K FLOOR PROTECT is straightforward and user-friendly. It is straightforward: mix the two components with a low-speed mixer until a homogenous color is achieved. It can be pigmented with water-based pastes and applied with a roller or spray at a rate of 150-300 grams per square meter in one or two coats. Ensure the first coat is dry before applying the second to avoid defects.

Disclaimer: Make sure not to disturb applied material with excessive rolling as roll marks may appear. The material is relatively fast drying and therefore any additional rolling after the first application will cause surface defects to appear. Make sure the first coat is completely dry before second coat is applied.

TYPES OF APPLICATIONS

APPLICATION BY COATS

Per coat: 0.150 kg/m².

Apply more coats depending on project requirements and system build-up.

PIGMENTATION OF AQUASMART-TC-2K-POOL PROTECT

The material is easily pigmented by using water-based pigment pastes available in hardware stores. At a maximum ratio of 10% by weight, the water-based pigments offer high hiding power to the transparent or white versions of the product. Pour the PIGMENT content of the pail into the product at a maximum ratio of 10% by weight. Mix thoroughly using a low-speed electric mixer until the product homogenizes. Apply the product as per standard application instructions.

APPLICATION WITH AIRLESS (200- 250 bar) SPRAY MACHINE.

1. Open the pail and stir it up to homogenize. Stirring can either be done manually or with a low speed (300 rpm) mixer.
2. If necessary, add up to 5% water into the pail and mix it with low-speed mechanical equipment.
3. Apply thin layers using an airless spray machine.
4. Wait for the recoat time.
5. Repeat this process until the desired or recommended thickness.

CLEANING

Clean tools and equipment first with paper towels. Tools and equipment should be cleaned immediately using SOLVENT-01 (or water for water-based materials). Rollers will not be re-usable.

REPAIR, OVERLAPS PROCESSES

LOCAL REPAIRS

One of the benefits of ALCHIMICA's liquid applied waterproofing systems is the ease of reparations to be carried out when spot problems occur. Nevertheless, it is always recommended to protect the membrane by ensuring that there are no foreign objects, sharp and heavy ones mostly, that they could fall and damage the membrane, to the best possible extent.



In cases where the membrane repair is caused by an accident or assembly procedures that are not covered by the installation, the following procedures must be followed:

- Grind the affected areas or remove the affected area and/or damaged surface by cutting.
- Sanding this area for overlapping, extending it about 20-30 cm around the perimeter.
- Clean the surface around the slit at a perimeter of 20-30cm depending on the repair length. Clean up thoroughly and remove all contaminants from the elements, such as dust or chippings, by mopping and/or vacuuming.
- If necessary, solvent wipe the area with a SOLVENT-01. Allow it to dry completely. The surface must be completely dry before the next steps.
- Apply a thin layer of primer MICROSEALER-50 at a consumption of 50-60gr/m² by overlapping the membrane at the prementioned perimeter.
- Fill the area by using HYPERSEAL®-EXPERT- 150, tool it to form a smooth patch, and the next day apply the same coat and topcoat that was applied to the rest of the membrane waterproofing system (if one was used) in order to ensure long term UV protection of the patch.
- In severe situations, the coating may have to be totally removed prior to system



re-application.

OVERLAPS

In cases where the recoat time (24-48 hours) has been exceeded, the waiting time between jobs has been extended, or unexpected weather conditions (rain) have stopped the application, proceed as follows:

The HYPERDESMO® SURFACE should be clean and free of loose particles and dust. If it rains after the first main coat application, you may need to solvent wipe the area and apply one thin coat of primer again.

- OPTION 1: clean the area and apply primer MICROSEALER-50 at the consumption of 50-80gr/m² in order to secure adhesion. After 6-12h you can apply the next coat of HYPERDESMO®.
- OPTION 2: solvent wipe the whole area with SOLVENT-01, let it dry, and then apply AQUASMART-DUR primer at 50-80gr/m² in order to secure adhesion. After 3-6h you can apply the next coat of HYPERDESMO®.

MAINTENANCE

- a. Surfaces may be cleaned with commercial detergents. ALCHIMICA recommends that a maintenance service contract be established between the project owner and the applicator.
- b. Regular inspection and repair of damaged surfaces will considerably prolong the performance and the expected life of the waterproofing system.
- c. Portions of the membrane that exhibit wear are considered an item of maintenance and not an item of warranty.
- d. All sharp debris such as gravel, sand and metal should be removed on a regular basis to avoid damage to the coating.
- e. When removing snow, avoid the use of metal blades or buckets that could damage the coating.



REFERENCES

ALCHIMICA, throughout the years, has a collection of completed projects from around the world. On our website, you can find where we have provided a variety of solutions and expert know-how, in case studies ranging from the smallest roof to the largest project. www.alchimica.com

HEALTH AND SAFETY

The system proposal contains volatile flammable solvents. Apply in well-ventilated, no-smoking areas, away from naked flames. In closed spaces use ventilators and carbon-active masks. Keep in mind that solvents are heavier than air, so they float near the floor. The MSDS (Material Safety Data Sheet) of the products are available on request.

This handling safety advice is required for the implementation procedure as well as in the pre- and post-exposure to the loading machinery.

- Protect your lungs by using an air-purifying respirator when handling or spraying.
- Use rubber gloves to protect your skin and remove them promptly after contamination. Wear clean undergarments. After work and before eating, drinking, or smoking, thoroughly wash your hands with soap and water.
- Wear safety goggles to protect your eyes and face from splashes and airborne particles.
- Waste generation should be avoided or reduced.
- Incinerate under well-controlled conditions in line with local and national rules and regulations.
- Re-occupancy of the work site without respiratory equipment is limited to 24 hours if proper ventilation for the sprayed area is provided.
- Contractors and applicators must follow all applicable and necessary storage and safety regulations.
- In any case, review the system's material and safety data sheets.

PRECAUTIONS AND VARIATIONS.

The purchaser must determine the suitability of the products for the intended use and assume all related liabilities and risks. This information, recommendations, and any additional technical advice are given in good faith and are based on ALCHIMICA's present knowledge and experience of the products when properly stored, handled, and applied under normal conditions according to ALCHIMICA's recommendations.

However, ALCHIMICA assumes no liability for providing such information and advice including the extent to which such information and advice may relate to existing third-party intellectual property rights, especially patent rights, nor shall any legal relationship be created by or arise from the provision of such information and advice. ALCHIMICA reserves the right to change at any time the properties of its products. The purchaser of the product(s) must test the product(s) suitability for the intended application and purpose before proceeding with a full application of the product(s).

The performance of the products build up described herein should be verified by testing and carried out by qualified experts.

NOTE: This method statement is offered by ALCHIMICA as a 'summary proposal' for **INDOOR CAR PARK SOLUTION BASED ON HYPERFLOOR-2K** For projects' particularities and more precise technical support, please contact ALCHIMICA at: alchimica@alchimica.com

Please consult the above-referred products' technical data sheets (TDS) and safety data sheets (SDS). Under any circumstances, ALCHIMICA does not assume any responsibility for the performance of the waterproofing system given the conceptual flaws of the existing build-up. Imperative for the performance of the system is the correct cleaning, inspection, and maintenance of the waterproofing system. For projects' particularities and more precise technical support, please contact ALCHIMICA at: alchimica@alchimica.com

Where alternative systems are to be used, these must be submitted to ALCHIMICA for approval. ALCHIMICA will not accept responsibility or liability for variations to the above under any other condition.

LEGAL NOTES AND CITATION

- This is a technical document, without legal value.
- No liability or warranty of product performance is created by this document.
- All the information included is collected from materials TDS, DoP, and certificates available at the moment of publishing.
- ALCHIMICA S.A. does not guarantee the accuracy of its instructions or specifications, nor do we assume any responsibility for damages resulting from the use or reference of the information provided. The company reserves the right to change the properties of its products at any time, and the current version of the technical data sheet is available on the website www.alchimica.com/en
- Appropriate Technical Documentation and/or Specific Technical Documentation: The performance of the products identified in the DoP files conform with the set of declared performances. This declaration of performance is issued in accordance with Regulation (EU) No 305/2011, under the sole responsibility of the manufacturer.
- It is recommended to check the TDS and MSDS of all the materials before use and application.
- The use of these materials and products is beyond the scope and control of ALCHIMICA.
- Proper application is the responsibility of the Buyer and/or Contractor.
- It is forbidden to reproduce it in any form, totally or partially.
- All the above written and provided is subject to the terms and conditions of sale and marketing of ALCHIMICA S.A.

ALCHIMICA S.A.

7, Lampsakou Str.

115 28, Athens Greece

Tel.: +30 214 4167 700

Fax: +30 214 4167 701

www.alchimica.com